



INSTALLATION AND SERVICE MANUAL

EPP SERIES – INDIRECT WATER HEATERS

FOR MODELS EPP-40 TO EPP-120
SEE REAR COVER FOR INDEX



WARNING

Read this instruction manual before installation, operation, or service. Failure to follow the instructions in this manual may result in severe personal injury, death or substantial property damage. Installation and service must be performed by a qualified service technician.

Manufactured by
Allied Technologies

Division of E-Z-Rect Manufacturing Ltd.

Manufacturers of Gas and Electric Boilers, Heat Exchangers, Electric Boosters, Indirect Tanks
94 Riverside Drive, North Vancouver, B.C. V7H 2M6 • Telephone 604-929-1214 • www.alliedboilers.com
Branches: Calgary • Edmonton • Toronto • Denver



DIMENSIONS AND SPECIFICATIONS

Storage Sizes (Nominal)	
EPP-40-SC	40 US Gal.
EPP-60-SC	60 US Gal.
EPP-60-SCR	60 US Gal.
EPP-60-DC	60 US Gal.
EPP-80-SC	80 US Gal.
EPP-80-DC	80 US Gal.
EPP-120-SC	120 US Gal.
EPP-120-DC	120 US Gal.
SC = Single Coil	
DC = Double Coil	
SCR = Crawl Space Design (Single Coil)	

Features	Quality Construction
<ul style="list-style-type: none"> • Fast Recovery Time • Highest Heat Transfer Efficiency • Low Standby Loss • Easy Installation • Warranty: 10 Year for Residential. See warranty for details. 	<ul style="list-style-type: none"> • AISI 316L Stainless Steel Tank • AISI 316L Stainless Steel Heat Exchanger • Aquastat and Stainless Steel Thermowell • Magnesium Anode • Passivated for additional Corrosion Protection

Notes: Single Coil heat exchanger uses 1" O.D. x 30 ft long Stainless Steel tube
 Maximum Operating Pressure: 150 psi
 Maximum Tank Temperature: 150°F
 Maximum Coil Temperature: 210°F

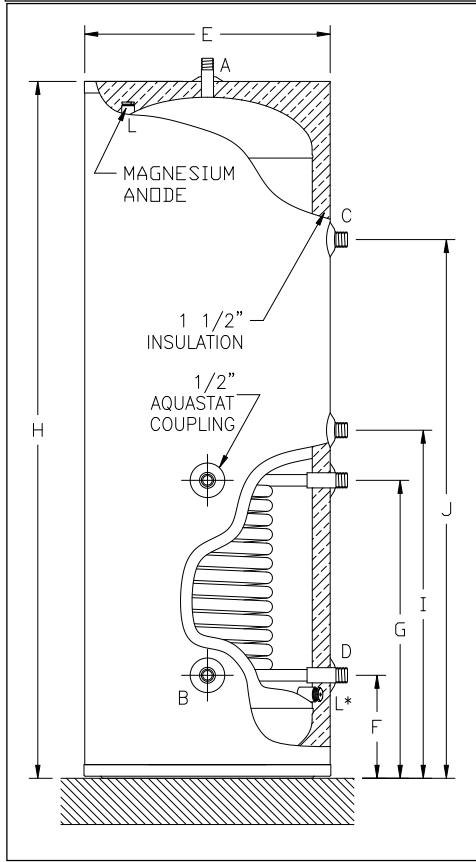

Model Number	Inlet From Boiler Temp.°F	(Based on Boiler Flow Rate of 10 GPM)			Thermal Input Requirements Btu/Hr
		1 st 10 Min. Delivery @ 135 °F US Gal.	1 st Hour Delivery @ 135 °F US Gal.	Continuous Delivery @115 °F US GPH	
EPP-40-SC	200	66	194	226	129,000
	190	63	176	205	117,000
	180	60	159	184	105,000
EPP-60-SC	200	86	214	226	129,000
	190	83	196	205	117,000
	180	80	179	184	105,000
EPP-60-SCR	200	86	214	226	129,000
	190	83	196	205	117,000
	180	80	179	184	105,000
EPP-60-DC	200	102	313	383	219,000
	190	97	284	346	198,000
	180	92	253	309	176,000
EPP-80-SC	200	105	232	226	129,000
	190	102	215	205	117,000
	180	100	198	184	105,000
EPP-80-DC	200	122	333	383	219,000
	190	117	304	346	198,000
	180	112	273	309	176,000
EPP-120-SC	200	146	274	226	129,000
	190	143	256	205	117,000
	180	140	239	184	105,000
EPP-120-DC	200	163	375	383	219,000
	190	157	345	346	198,000
	180	152	314	309	176,000

	Dimensions						Fitting Sizes				Shipping Weight
	E	F	G	H	I	J	A Hot Water Outlet	B Cold Water Inlet	C Inlet from Boiler	D Outlet to Boiler	
EPP-40-SC	21"	7 5/8"	24 1/8"	42 5/16"	-	-	3/4"	3/4"	1"	1"	144 LB
EPP-60-SC	21"	7 5/8"	24 1/8"	60 5/16"	-	-	3/4"	3/4"	1"	1"	182 LB
EPP-60-SCR*	27"	10 13/16"	27 5/16"	36 3/8"	-	-	3/4"	3/4"	1"	1"	164 LB
EPP-60-DC	21"	7 5/8"	24 1/8"	60 5/16"	30 1/8"	46 5/8"	3/4"	3/4"	1"	1"	196 LB
EPP-80-SC	23"	10 1/4"	26 3/4"	63 5/16"	-	-	1"	1"	1"	1"	198 LB
EPP-80-DC	23"	10 1/4"	26 3/4"	63 5/16"	32 7/8"	49 1/4"	1"	1"	1"	1"	212 LB
EPP-120-SC	27"	10 11/16"	27 3/16"	64 5/8"	-	-	1 1/2"	1 1/2"	1"	1"	236 LB
EPP-120-DC	27"	10 11/16"	27 3/16"	64 5/8"	33 3/16"	49 11/16"	1 1/2"	1 1/2"	1"	1"	256 LB

* Anode for EPP-60-SCR located at lower end of tank instead of top.
 Also available:
 • "Stacker" Indirect Fired Hot Water Tank in 40 US gallon – boiler can be stacked on casing to save floor space
 • EPP Storage Tanks in 40, 60, 80, and 120 US gallon
 The Super Hot product improvement program may result in changes to design and/or specifications being made without notice.



Pre-Installation

Section 1

1.1 RECEIVING

INSPECT SHIPMENT FOR POSSIBLE DAMAGE. All goods are carefully manufactured, inspected, checked and packed by experienced workers. The manufacturer's responsibility ceases upon delivery of goods to the carrier in good condition. Any claims for damage and/or shortage in shipment or non-delivery must be filed immediately against the carrier by the consignee.

Use care when receiving and unpacking the tank. Dropping the tank may cause damage and prevent safe and proper operation.

1.2 INSTALLATION CODES AND REQUIREMENTS

All applicable national, provincial/state, and local codes, laws, regulations, and ordinances must be followed. They expand on and take precedence over any recommendations in this booklet. Authorities having jurisdiction shall be consulted before installations are made.

If an external electrical source is utilized, the hot water tank, when installed, must be electrically grounded in accordance with local codes or, in the absence of local codes, with the *National Electrical Code, ANSI/NFPA 70* (current edition) and/or the *Canadian Electrical Code, CSA C22.1 Part 1* (current edition).

If there is any conflict in the above requirements, the more stringent requirement applies.

The installation and service must also conform to the additional requirements in this manual. If there is any conflict with a requirement in this manual and a code requirement, the code requirement must be followed.

1.3 LOCATION

- **DANGER - Risk of Explosion:** Do not use or store gasoline or other flammable fuels or chemicals which have flammable vapors near the tank. The vapors may be ignited by the heat or electronic components of the tank.
- **WARNING:** The tank should be located in an area where leakage of the indirect water heater or connections will not result in damage to the area adjacent to the appliance or to lower floors of the structure. When such locations cannot be avoided, it is recommended that a suitable drain pan, adequately drained (connected to a drain of adequate capacity), be installed under the tank. Failure to comply with the above could result in severe personal injury, death or substantial property damage.
- **WARNING:** Failure to support and stabilize the water heater could result in severe personal injury, death or substantial property damage. Do not lean items against the water heater. Avoid unnecessary contact with the water heater.
- This tank should not be placed where freezing might occur and is not to be installed outdoors.
- This tank is designed for vertical installation. Install the tank on an area that is stable, flat, level and capable of supporting the weight of the tank when filled with water.
- Although minimal clearance is required for this tank, ensure that there is sufficient room for the water heater to access all of the fittings easily. We recommend a **service clearance of 24"** around plumbing connections.
- This tank must be installed such that any electronic components are protected from water (dripping, spraying, rain, etc.) during appliance operation and service.
- Avoid heat loss and friction loss by locating the tank as close to the boiler as possible. Further heat loss should be avoided by insulating the pipe.
- For the fastest delivery of hot water, locate the water heater in a position central to the points of use.



1.4 OPERATING RESTRICTIONS

WARNING: Single wall heat exchangers must use a heat transfer medium such as water or other non-toxic fluids having a toxicity rating of Class 1, as listed in Clinical Toxicology of Commercial Products (current edition). The pressure of the heat transfer medium must be limited to a maximum of 150psi by an approved pressure relief valve.

- Maximum working pressure of the tank: 150psi
- Maximum coil temperature: 210°F
- Maximum tank temperature: 150°F

1.5 WATER QUALITY

Always use good quality water to prolong the life of the tank. Water that is safe to drink and even city water is not necessarily good quality water for the tank. The use of filters can prevent corrosion and reduce sediment inside the tank. Water hardness, pH, and chlorides must be controlled to normal levels.

- **PH levels must be between 6.0 and 8.0**
- **Chlorine, chlorides and aggressive sulfates concentrations must be below 100 parts per million**

If you are unsure, use a water softening system or consult a qualified water treatment expert.

NOTE: All improper use as detailed above could void the warranty of the tank.



Piping and Plumbing

Section 2

2.1 BOILER SIDE PLUMBING

Connect boiler out (hot) supply piping to the fitting marked “boiler in” on the water tank. The “boiler out” fitting on the tank should be piped to the boiler return. Use Teflon tape, pipe dope, or both on all threaded fittings. When installing the pump make sure that the direction arrow is pointing in the same direction as the flow. The use of shut off valves and dielectric unions are recommended when installing your water tank to simplify future service requirements.

To prevent gravity flow and heat loss from the water heater, it is recommended a check valve be installed as close as possible to the higher connection of the coil (and both coils for a double coil design).

The heat output of the tank is based on the *temperature* and *flow rate* from the boiler supply. To ensure that the minimum flow rate is provided, use at least 1 inch pipe size to connect the boiler to the tank, and a zone valve with a minimum 1 inch diameter and flow coefficient of at least $C_V = 8$.

Hot Water Priority

A boiler system connected to multiple zones may be installed so that domestic water heating will be given priority over other zone heating. If hot water priority is used, preventative measures must be taken to ensure hot water priority during cold weather conditions does not result in freezing damage to the other zones.

Sample Systems

Although there are unlimited possibilities for your indirect water heater system, some typical installations are described and shown below. Note that all heating zones can be controlled either by using circulators (pumps) or zone valves as long as correct flow is provided.

- Dedicated Single Boiler with Single Coil Tank**
- Radiant Floor / Baseboard with 3 Port Zone Valve – Domestic Priority**
- Radiant Floor / Baseboard with 2 Port Zone Valve – Domestic Priority**
- Radiant Floor / Baseboard Using Circulator and Domestic Hot Water Priority**
- Dedicated Single Boiler with Double Coil Tank**
- Radiant Floor or Hot Tub / Pool Using Double Coil Tank**
- Multiple Water Heaters – Domestic Priority**
- Multiple Water Heaters Piped in Series**

Standard Circulators Zone:

Run the same as a standard heating zone except one zone is piped to the water heater and can be prioritized by correct use of the control valve. Ensure that the circulator is sized correctly to allow the boiler water to flow at the correct rate.

Zone Valve System:

Run the same as a standard heating zone except one zone is piped to the water heater and can be prioritized with correct use of the zone valves. Ensure that the circulator is sized correctly to allow the boiler water to flow at the correct rate. Do not use a zone valve less than 1 inch diameter and $C_V = 8$.

3-way Zone Valve System:

For prioritizing your water heater, a 3-way zone valve can be installed into your system. This system overrides all other “calls for heat” when there is a demand from the water heater aquastat. All the boiler water is then diverted to the water heater. There are three ports on a 3-way valve: a common port, a normally closed port, and a normally open port. The common port is connected to the boiler side, the normally open port connected to the heating zone, and the normally closed port is connected to the water heater coil. The boiler water is able to flow through the heating zone until the water heater aquastat calls for heat. The zone valve is then activated and the boiler water is diverted to the water heater; once the requested water temperature is achieved, the aquastat will shut off power to the zone valve and the boiler water will be diverted back to the heating zone.



2.2 INSTALLATION DIAGRAMS

Sample Schematics Boiler Side Piping

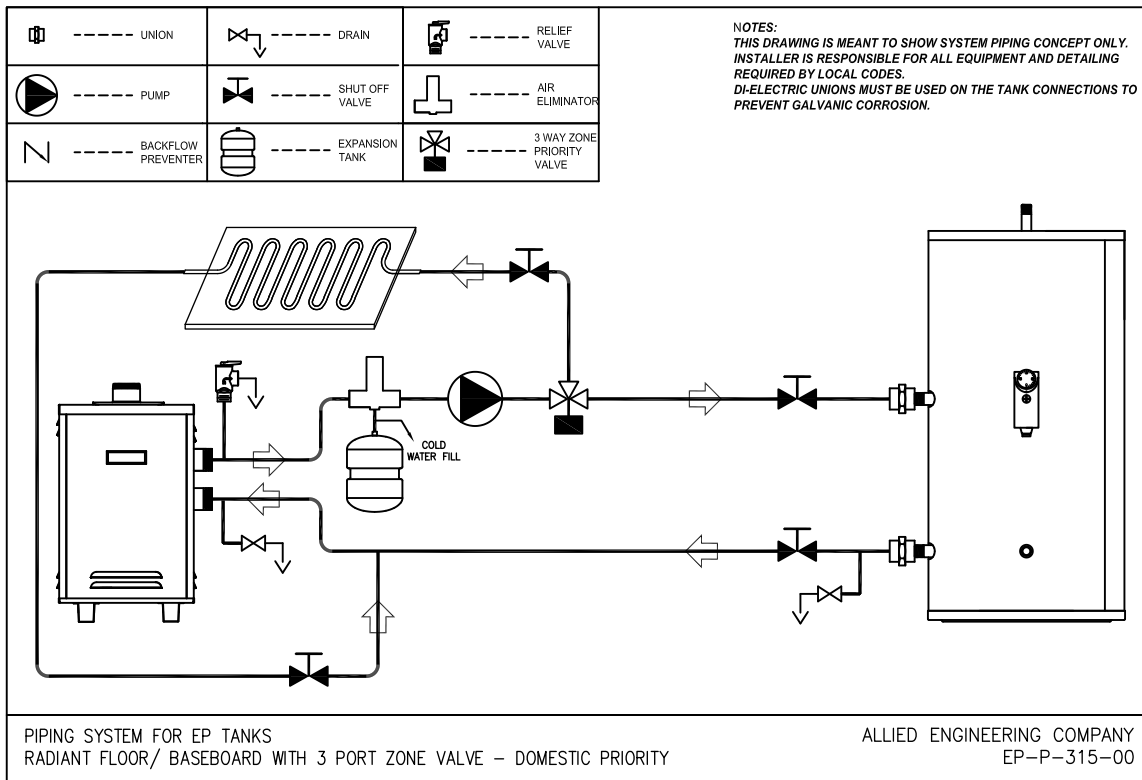
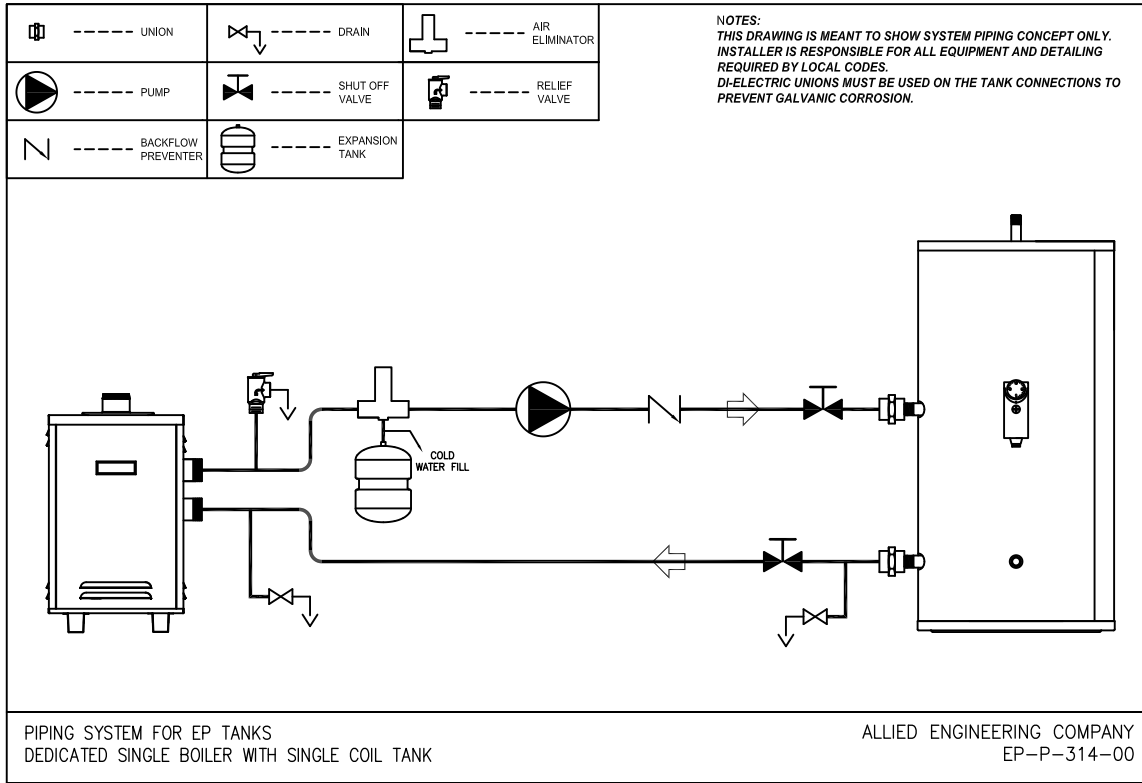

EPP SERIES INDIRECT WATER HEATERS – Installation and Service Manual

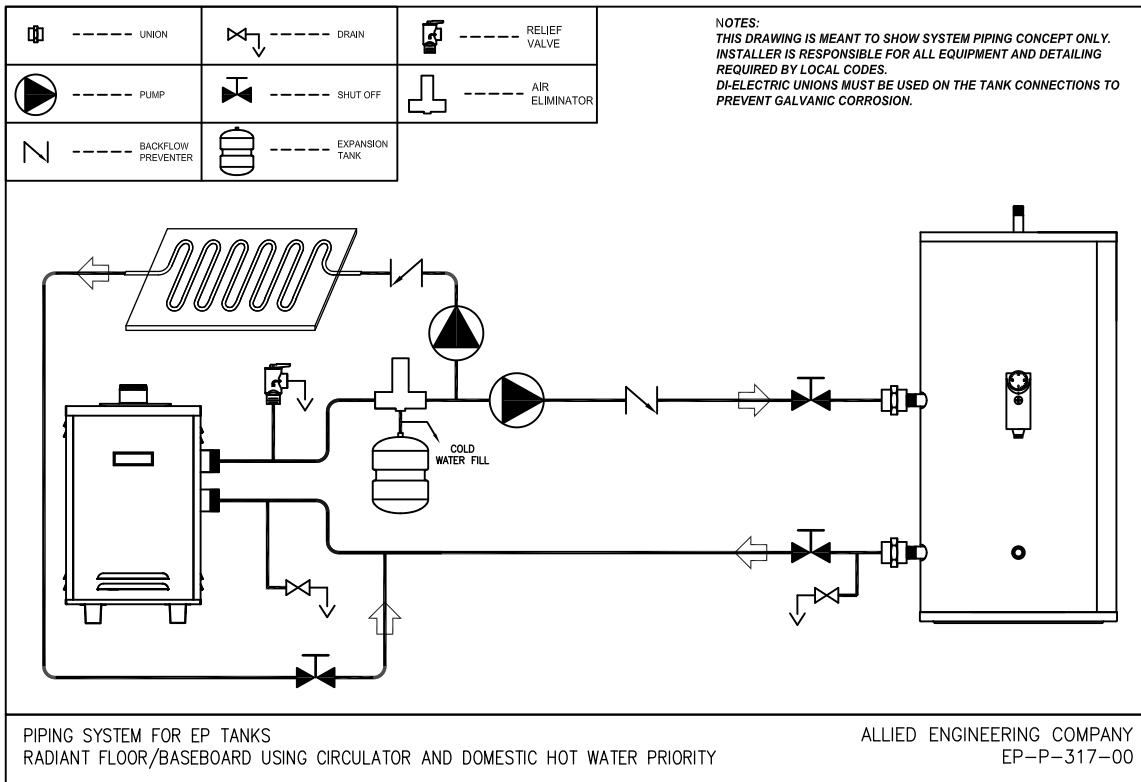
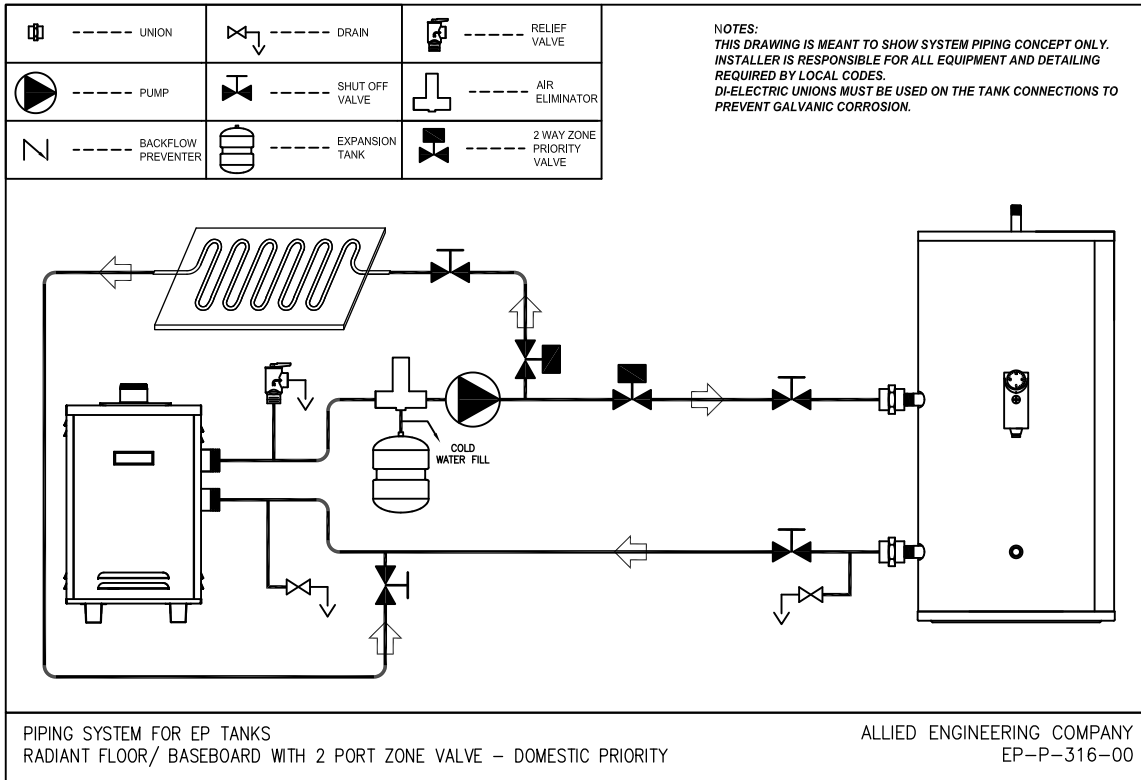

EPP SERIES INDIRECT WATER HEATERS – Installation and Service Manual



Double Coil for larger hot water demand

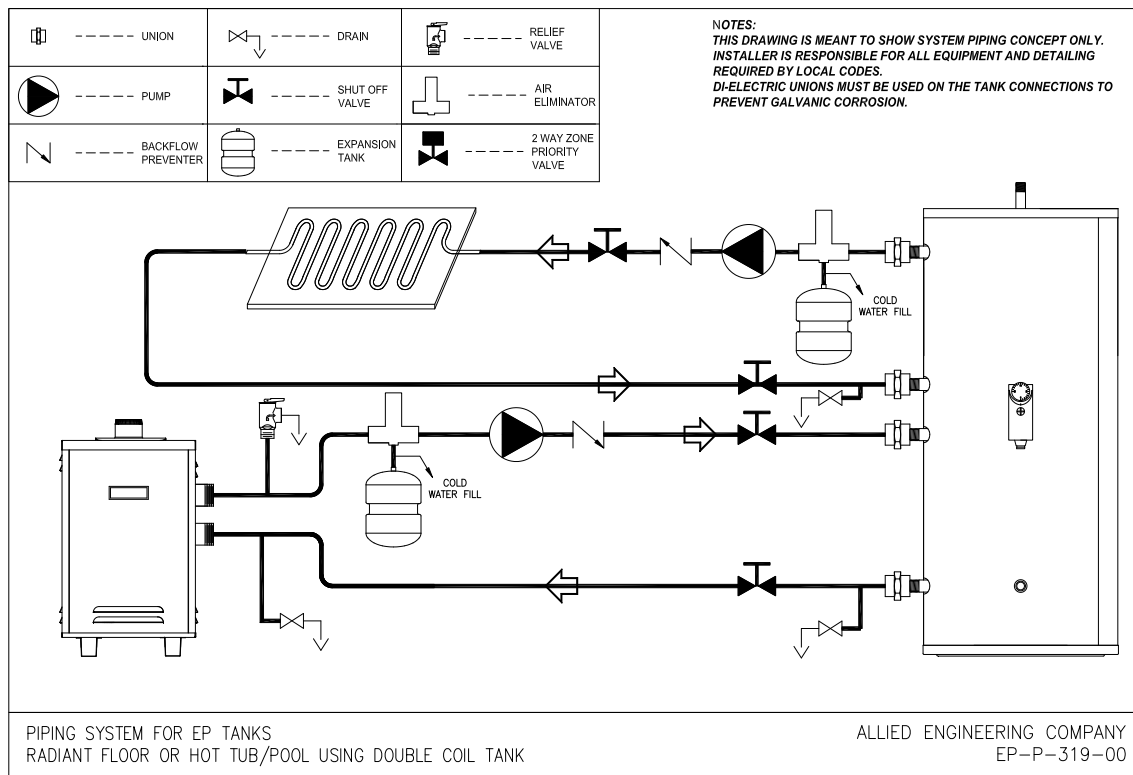
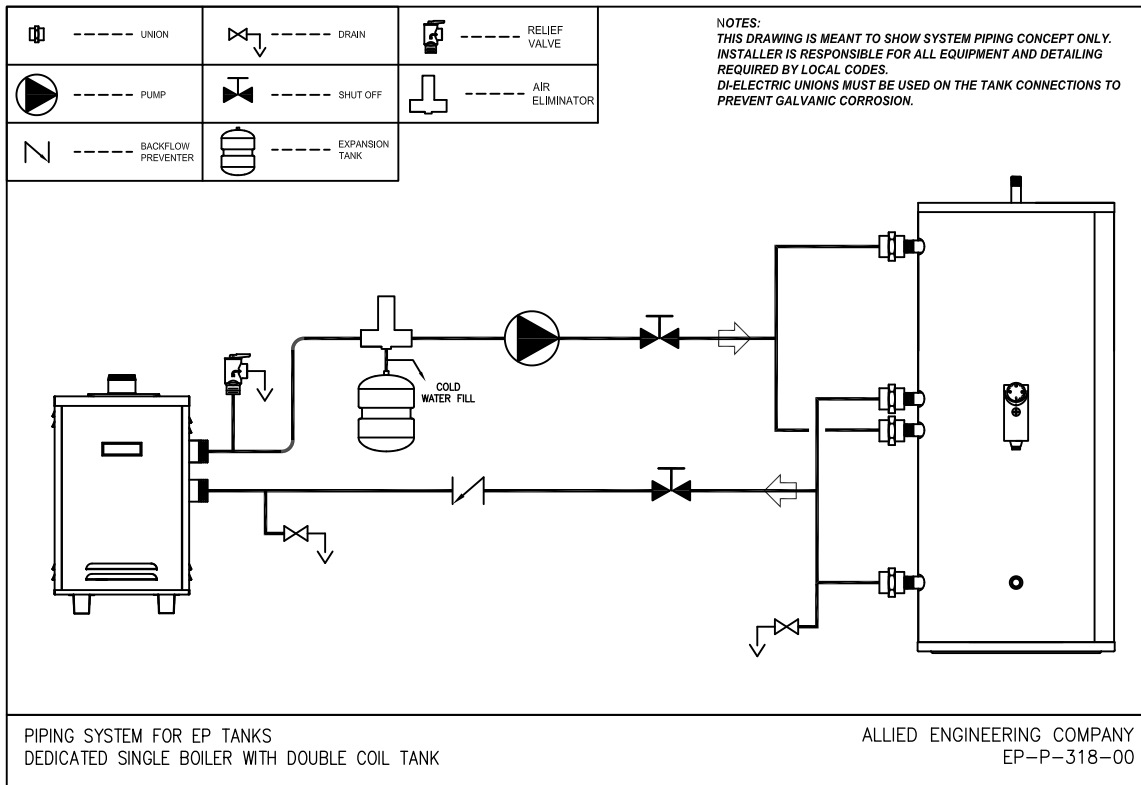

EPP SERIES INDIRECT WATER HEATERS – Installation and Service Manual



Multiple Water Heaters

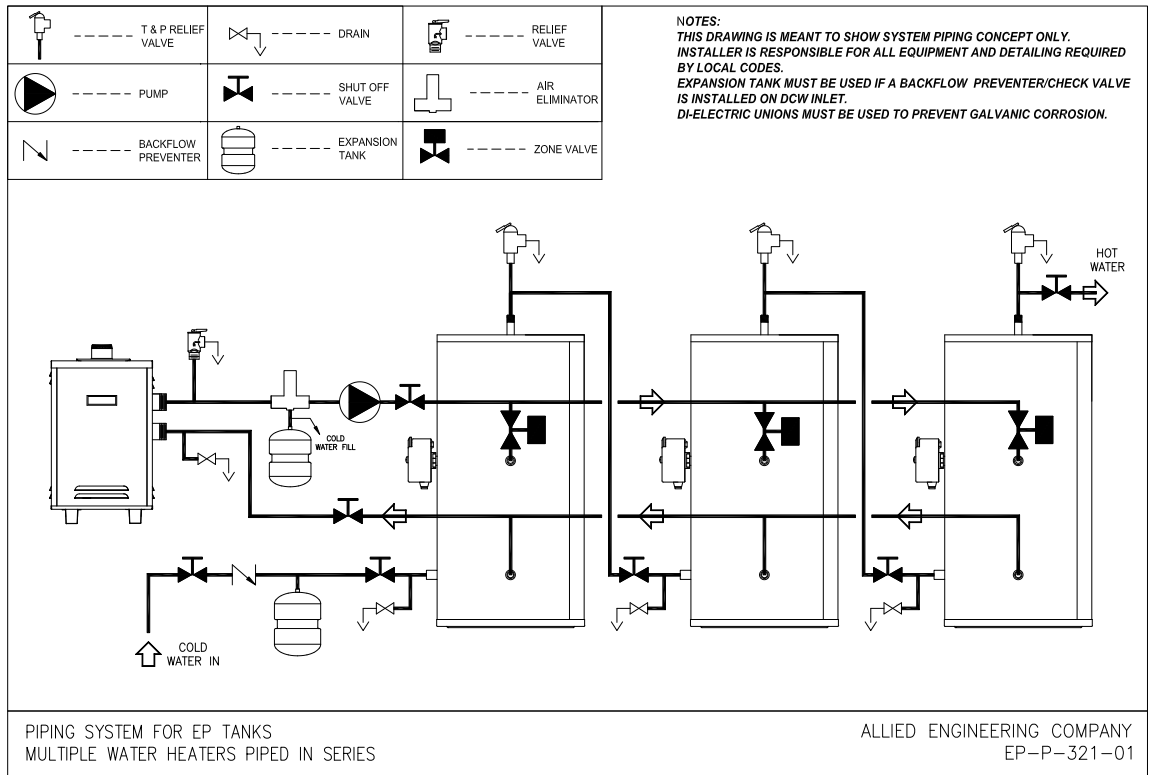
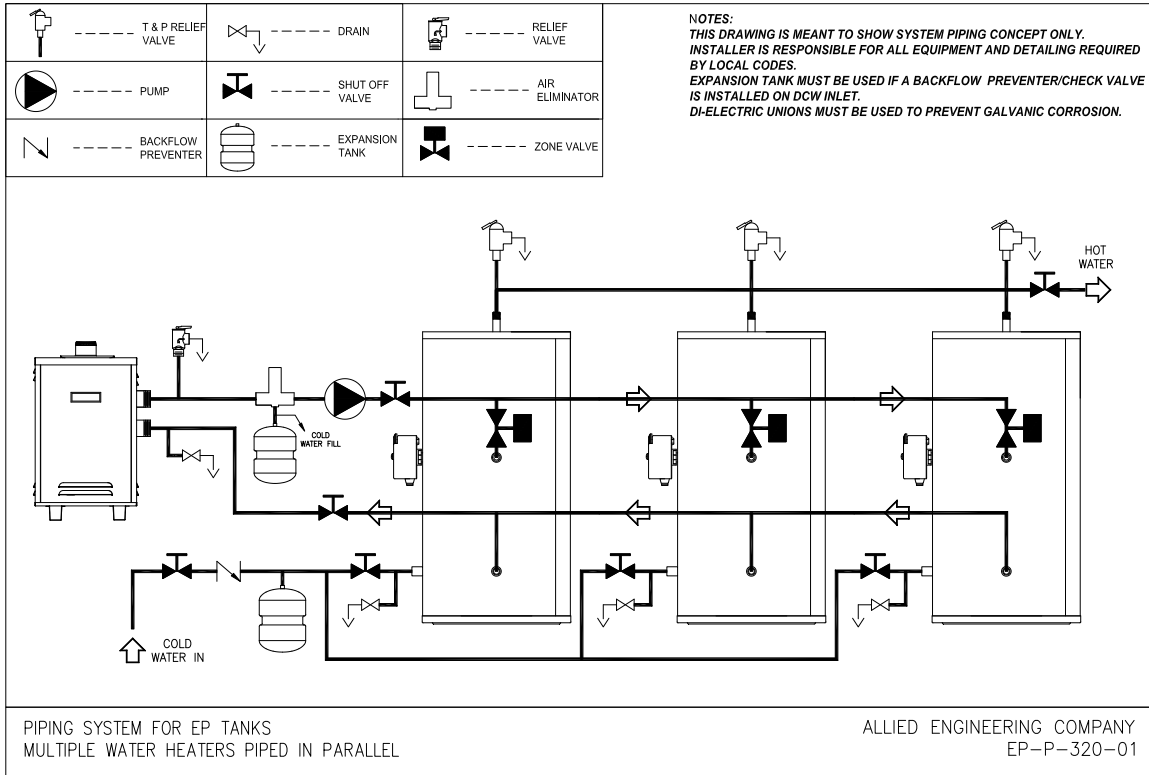



2.3 DOMESTIC SIDE PLUMBING

Connect domestic water in and domestic water out to the marked fittings on the water heater. Use Teflon tape, pipe dope suitable for domestic water, or both on all threaded fittings. Connect drain valve near the inlet connection so that the tank can be drained. Shut off valves and dielectric unions must be used when installing your water tank to simplify future service requirements and prevent galvanic corrosion.

To prevent gravity flow and heat loss from the water heater, it is recommended a thermal trap with a minimum 12 inch drop be installed on the tank outlet.

Check with local codes to determine if a vacuum breaker or backflow preventer must be installed. Install an expansion tank of adequate capacity if a backflow preventer, check valve, or pressure-reducing valve is installed on the cold-water inlet. Do not install any valve or restrictions between expansion tank and hot water tank inlet. Improper sizing or installation of the expansion tank can result in excessive pressure in the water heater and may result in severe personal injury, death or substantial damage to property.

Actual service pressure should not exceed that of pressure stamped on the T & P relief valve minus 25psi.

2.4 T&P RELIEF VALVE PLUMBING

DANGER – Risk of Explosion: A T&P (temperature and pressure) relief valve must be installed to protect the tank from excessive temperature and pressure. Do not plug T&P relief valve or discharge piping. Plugging T&P relief valve or discharge piping can cause excessive pressure in water heater, resulting in severe personal injury, death or substantial property damage.

WARNING: The T&P valve may discharge pressurized hot water and/or steam. Steam exiting the discharge outlet can explosively expand in any direction. Always maintain a safe distance from the discharge pipe outlet in order to avoid potential contact with exiting hot water or steam.

Temperature and pressure settings of the T&P relief valve are factory set and are not adjustable. The T&P valve must be of sized capacity to handle the maximum heat input to the indirect water tank and not greater than the operating restrictions stated on the rating plate of the indirect water heater and in this manual. Furthermore, the service pressure should be at least 25 psi less the setting stamped on the T&P relief valve.

Install the T&P relief valve directly into a tee on the hot water outlet of the tank so that the temperature sensing element is immersed in the water at the top of the tank. No valve, reducing coupling or other restriction is to be placed between the T&P relief valve and the tank connection. No valve, reducing coupling, pipe plug, pipe cap or other restriction is to be placed in the discharge piping. Improper placement or piping of the T&P relief valve can cause severe personal injury, death or substantial property damage.

The discharge line shall be installed to allow the complete drainage of both the valve and the line. It shall be independently supported or arranged so as to avoid undue stress on the valve. **Do not pipe in any area where freezing may occur.**

The termination of the T&P relief valve discharge line shall be downward and not directly connected to a sewer line. The outlet of the discharge line shall terminate in the vicinity of a point of drainage within 6” of the floor to eliminate potential risk of scalding and should terminate freely to atmosphere where any discharge will be clearly visible and is at no risk of freezing.

2.5 WATER HAMMER

Water hammer is a damaging pressure shock wave created when the flow of water is suddenly stopped or reduced (possibly induced by fast-closing faucet, reducing valve, or solenoid valve in a clothes/dish washing machine). This condition is commonly associated with hammering noises and vibrations; however, lack of noise does not assure that water hammer is not present. Risers or air chambers do not provide protection. To prevent damage to piping and the water heater: (1) install properly-sized water hammer arrestors at all required locations and (2) adequately size pipes to ensure a maximum water velocity less than 5 ft/s.



Domestic Side Piping Domestic piping with thermostatic mixing valve

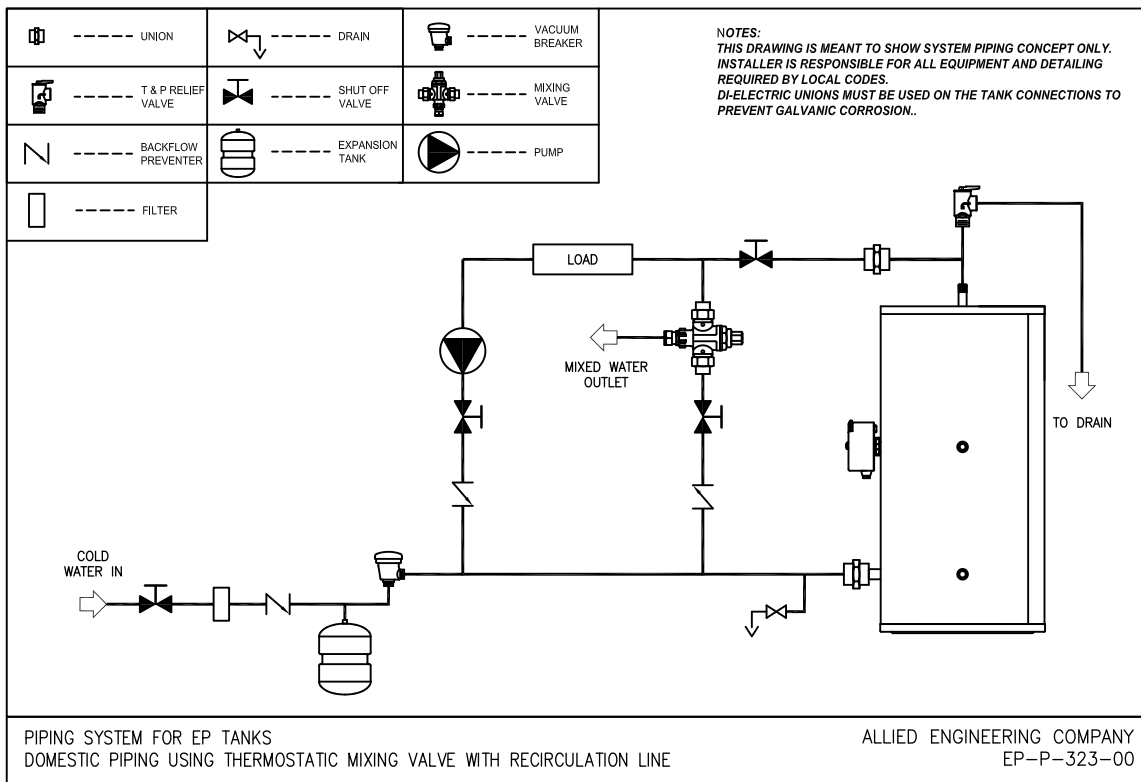
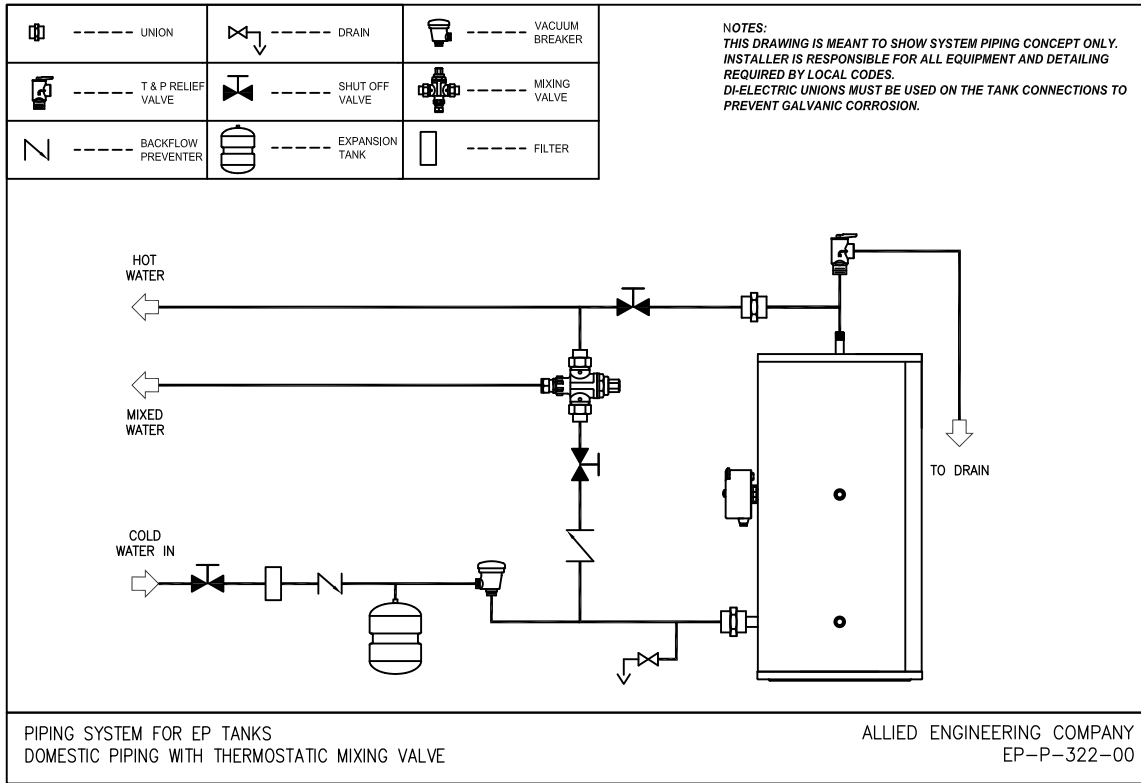



Wiring Diagrams

Section 3

WARNING: Turn off all the electric power before any wiring or service. All circuit breakers ahead of or related to the boiler and tank operation must be switched off.

CAUTION: Label all wires prior to disconnection when servicing controls. Wiring errors can cause improper and dangerous operation.

When installed the tank must be grounded in accordance with local codes or, in the absence of local codes, with the National Electrical Code ANSI/NFPA 70, and/or the CSA C22.1 Electrical Code.

All wiring is to be done in accordance with all applicable local and state/provincial codes. They expand on and take precedence over any recommendations in this manual.

Wiring for the aquastat is to be connected through the junction box below the aquastat opening. The aquastat is to be connected in parallel with the zone valve motor. For line voltage connections over 30 volts, wiring must be securely fastened at the junction box opening (not provided).

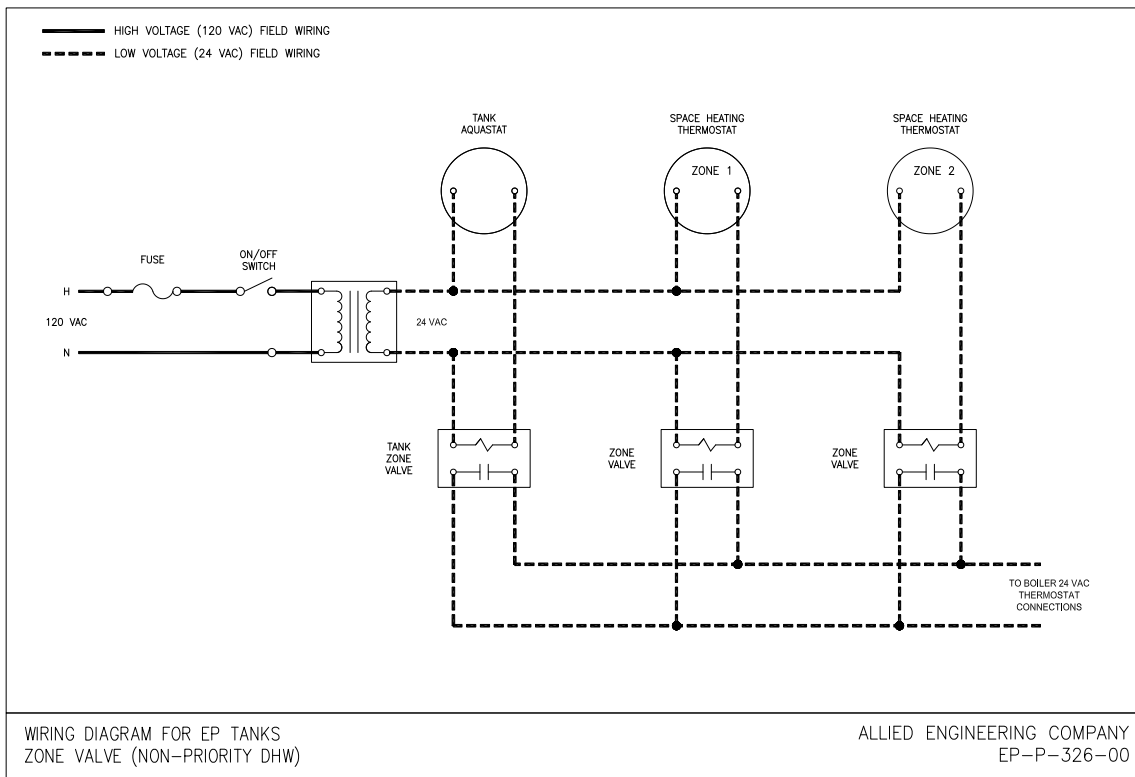

EPP SERIES INDIRECT WATER HEATERS – Installation and Service Manual

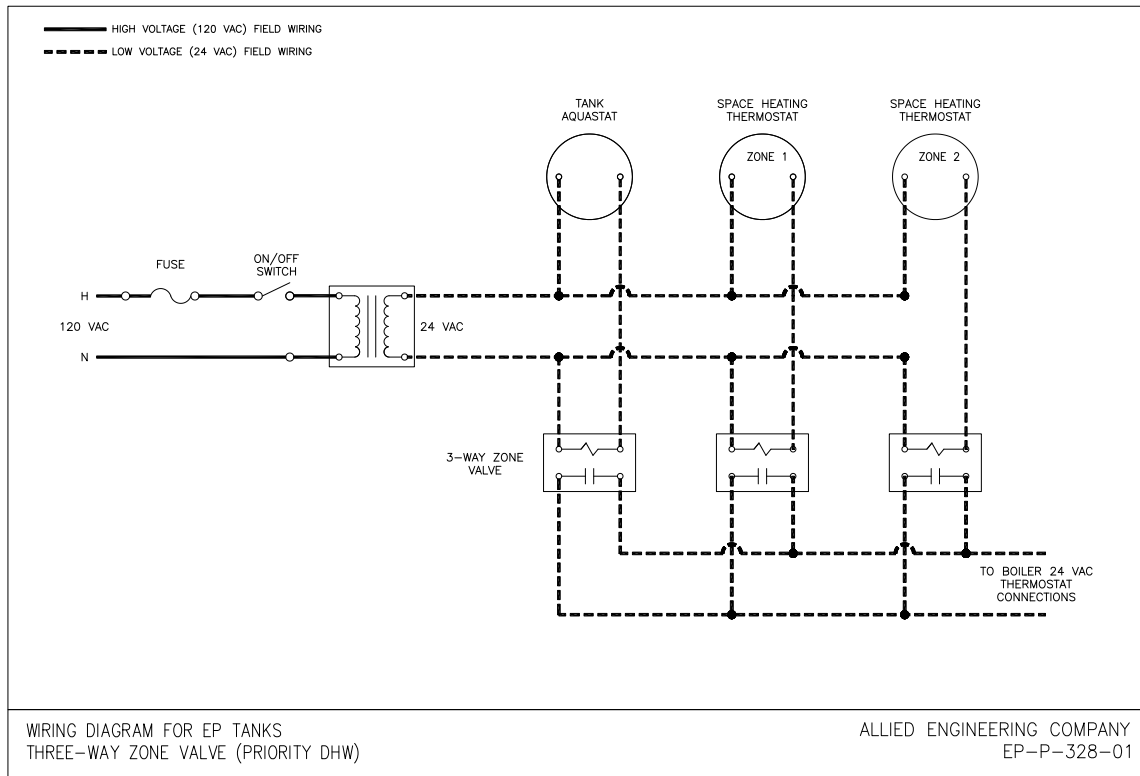
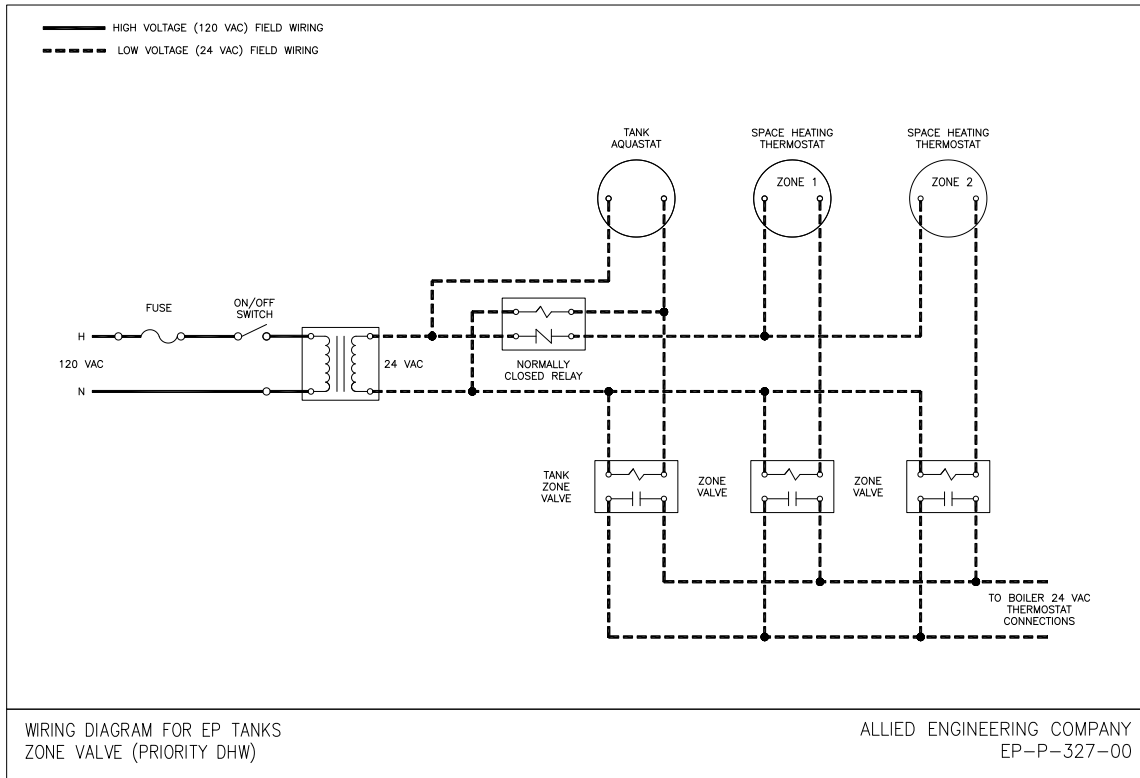

EPP SERIES INDIRECT WATER HEATERS – Installation and Service Manual

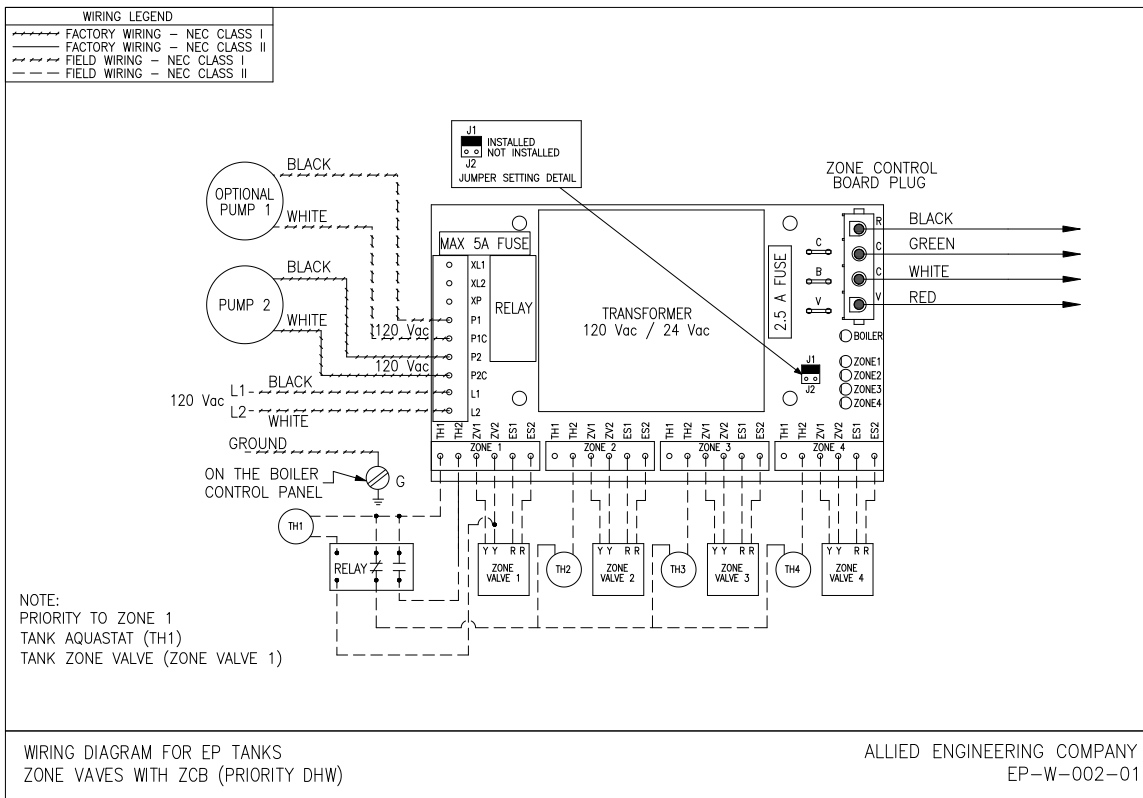
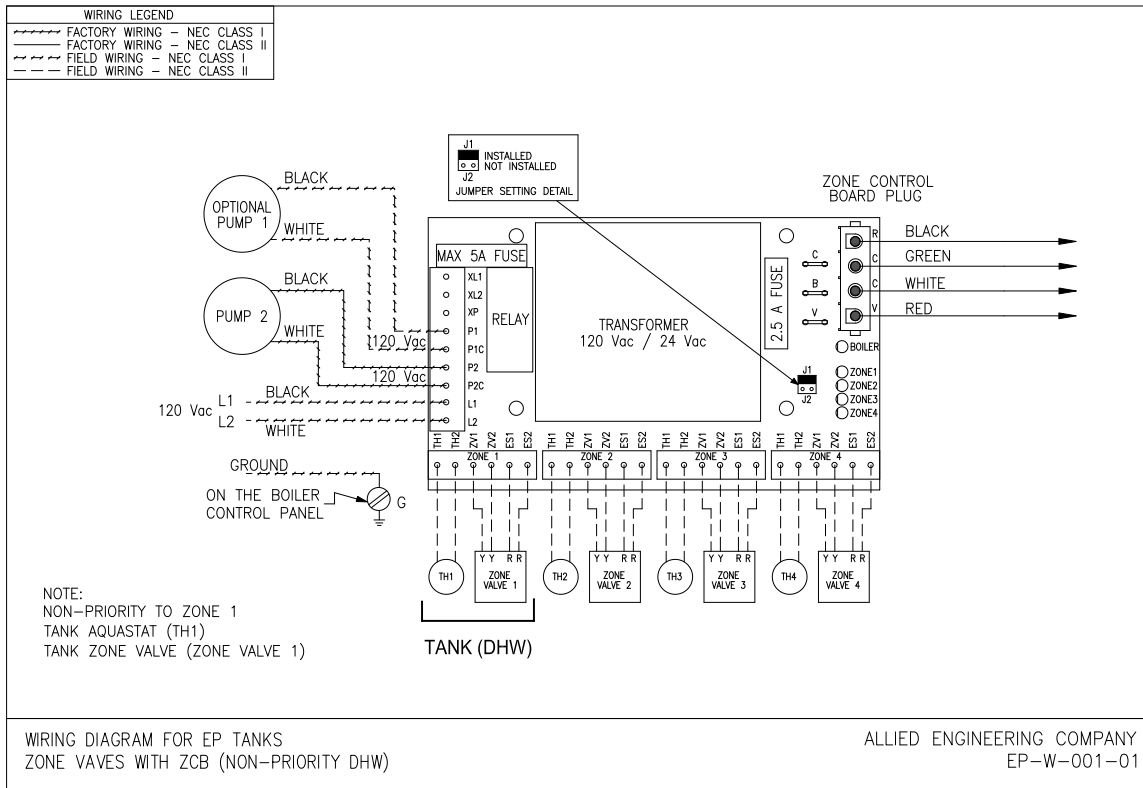

EPP SERIES INDIRECT WATER HEATERS – Installation and Service Manual

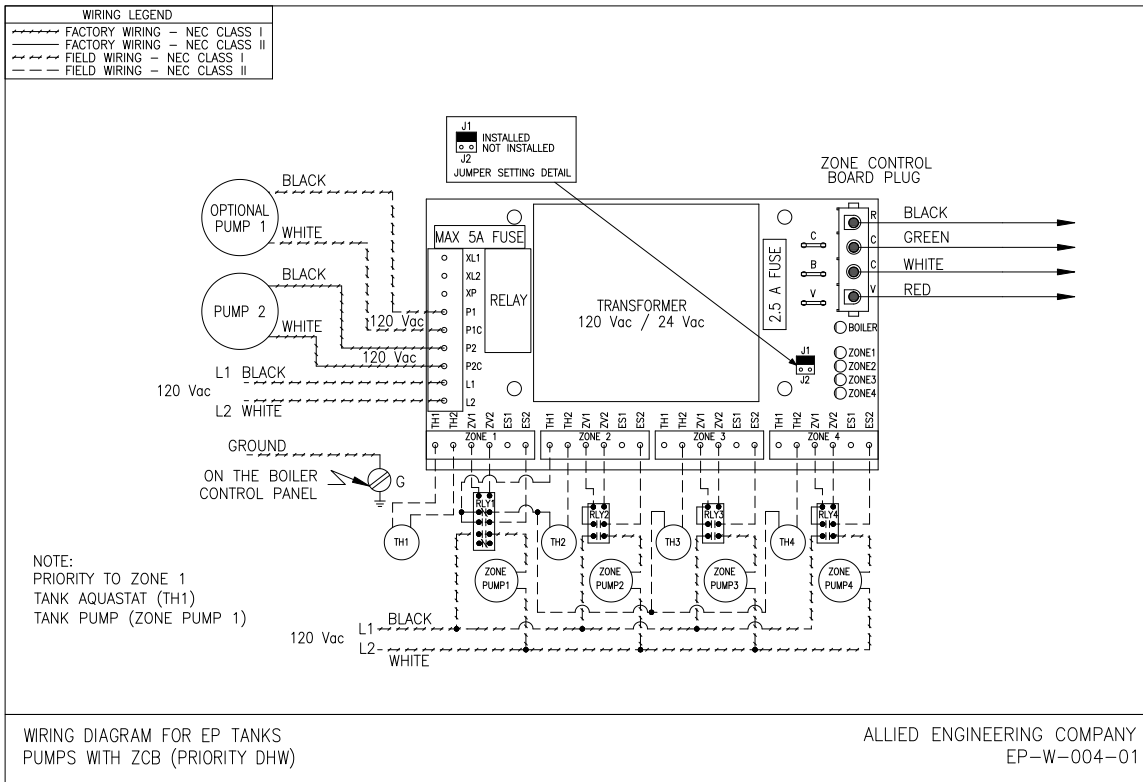
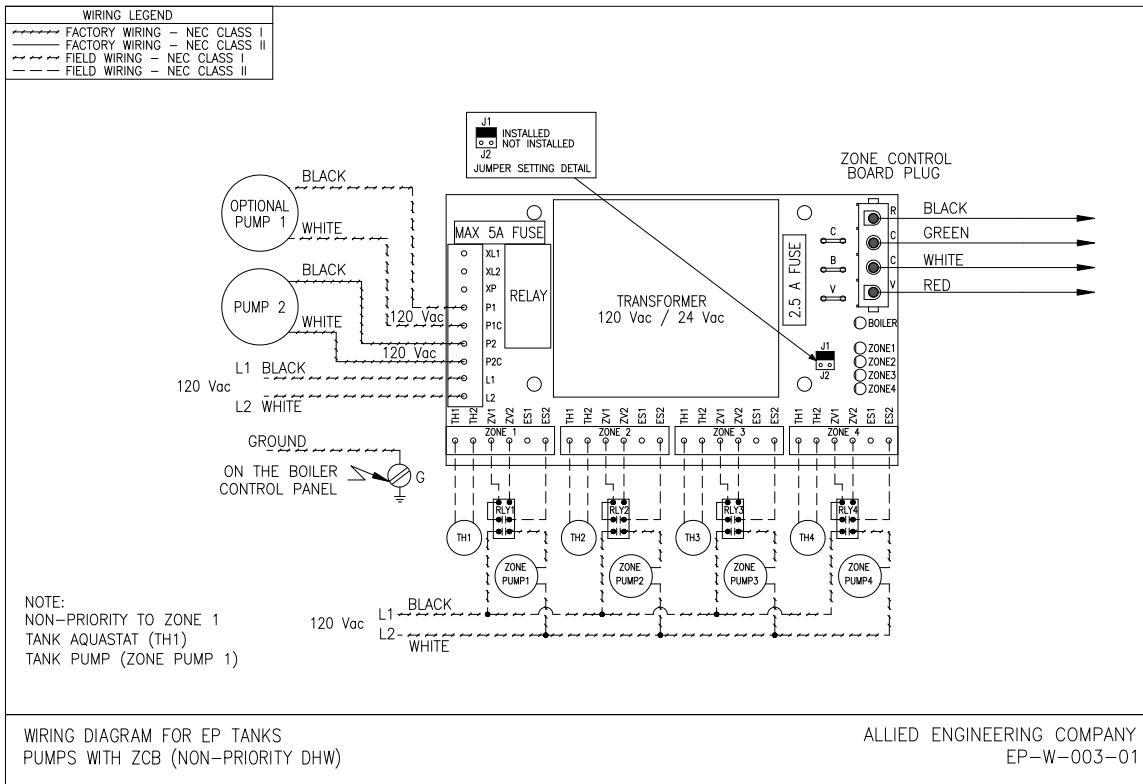

EPP SERIES INDIRECT WATER HEATERS – Installation and Service Manual

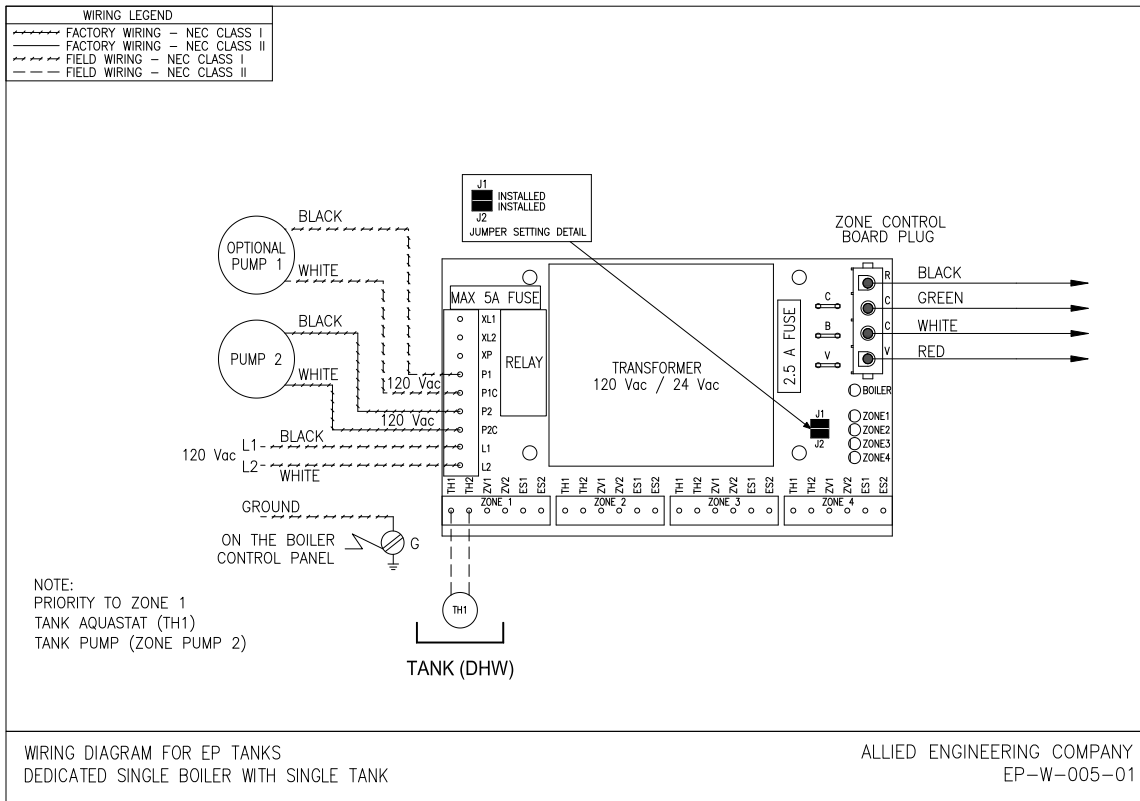



Startup and Adjustment

Section 4

DANGER: Before filling the tank, make sure that the T&P relief valve is installed and that the unit is properly grounded.

CAUTION: Never use tank until it is filled with water and connected to the domestic water piping and boiler piping.

4.1 PRE-START UP CHECKLIST

- T&P relief valve is properly installed and drain discharge is directed to a drain of adequate capacity.
- Domestic cold and hot water lines are correctly connected to domestic water system.
- Boiler supply and return piping is correctly connected from boiler to the tank.
- Domestic and boiler water systems are correctly pressurized.
- All wiring is installed correctly, no exposed high voltage wiring is present and the unit is properly grounded.

4.2 STARTUP INSTRUCTIONS

1. Make sure all electrical power is OFF.
2. Close the drain valve on tank.
3. Open domestic water supply valve.
4. Open the closest hot water faucet to vent air from the system.
5. Close faucet when there is a constant flow of water.
6. For boiler side piping, follow boiler instructions to purge air.
7. The tank, domestic water piping, and boiler water piping should be completely filled with water and all air extracted from both domestic and boiler water systems.
8. Set aquastat on water heater. The aquastat is adjusted to its lowest temperature setting when shipped from the factory.
9. Power up boiler (following boiler instructions) and water heater.
10. Check boiler is operating normally.
11. Check zone valve or circulator is in good condition.
12. Check all connections, fittings and piping for leaks.
13. Adjust the temperature at the faucets as described in the next section.



Water Adjustment **Section 5**

DANGER: Water Temperatures over 125°F (52°C) can cause severe burns instantly or death from scalds. Feel water before bathing and showering. Homes that have small children, elderly and disabled persons may wish to lower the water heater setting to 120°F (49°C) to prevent potential scalding. Below is a table showing the approximate time it takes to have a scalding accident for different temperatures of hot water:

Water Temperature	Length of Time to Cause Scalding
125°F (52°C)	1 1/2 to 2 minutes
130°F (54°C)	about 30 seconds
135°F (57°C)	about 10 seconds
140°F (60°C)	less than 5 seconds
145°F (63°C)	less than 3 seconds
150°F (66°C)	about 1 1/2 seconds



Maximum boiler water temperature is 210°F

A thermostatic mixing valve or tempering valve should be installed on the domestic hot water supply and set to a maximum of 120°F (49°C).

Valves for reducing point of use temperature by mixing cold and hot water are available. Consult a licensed plumber or local plumbing authority.

WARNING: Studies show that dangerous bacteria can form in domestic water distributions systems if a minimum water temperature is not maintained. For example, legionella pneumophila, can form in hot water maintained at 115°F (46°C) or lower. We recommend a domestic water temperature not lower than 122°F (50°C) at faucets and a tank temperature not lower than 140°F (60°C) to limit the potential for legionella pneumophila growth. Contact your local health authority for more information.

5.1 CONTROL/AQUASTAT

A control aquastat and thermowell must be installed in order to control the maximum temperature of the tank. Insert the control aquastat into the factory installed stainless steel well and secure it to the well by using the screw on the aquastat body. Thermal paste is recommended but not required.

The aquastat will control the tank water temperature within a close tolerance to the aquastat temperature setting, but unusual usage patterns may cause the outlet water temperature to rise significantly above the aquastat setting. To control fluctuating temperature, a thermostatic mixing valve (tempering valve) must be installed.

5.2 AQUASTAT TEMPERATURE

- Use the aquastat to control the maximum water temperature in the tank. Its differential is fixed at 5°F (3°C). Its maximum setting is 150°F (65°C).
- Household water usage patterns will affect water temperature at any faucet or shower. Always check temperature at every point after adjusting aquastat.
- When hot water is used in repeated small quantities the upper layer of water in tank can be much hotter than lower layers. When adjusting the aquastat, be sure boiler limit control is set a minimum 20°F (11°C) higher. However, in no case should boiler limit control be set above 210°F (99°C).
- Maximum tank temperature is 150°F.



5.3 TEMPERATURE ADJUSTMENT

Allow the water heater to operate several heat-up cycles and check the water temperature at the faucet to verify proper operation.

- If the water at the faucet is hotter than needed:
 1. Adjust the aquastat to a lower temperature setting or thermostatic mixing valve, if used.
 2. Draw sufficient water or allow the water to sit until another heat-up cycle is initiated.
 3. Wait until the heat-up cycle is completed.
 4. Recheck the water temperature at the faucet.
- If the water at the faucet is colder than needed:
 1. Adjust the aquastat to a higher temperature setting.
 2. If a heat-up cycle begins, wait until the heat-up cycle is completed and recheck the water temperature at the faucet.
 3. If a heat-up does not begin, draw sufficient water or allow the water to sit until a heat-up cycle is initiated. Wait until the heat-up cycle is completed. Recheck the water temperature at the faucet.



Service and Maintenance

Section 6

The *EPP Series Indirect Hot Water Tank* has been designed to provide years of trouble-free performance in normal installations and requires minimal routine maintenance to ensure a reliable and safe supply of hot water.

6.1 GENERAL OPERATION

- **DANGER:** Before operating the T&P relief valve, make sure no person is near the T&P relief valve discharging piping.
- **DANGER:** Do not plug T&P relief valve or discharge piping. Plugging T&P relief valve or discharge piping can cause excessive pressure in water heater resulting in severe personal injury, death or substantial property damage.
- **WARNING:** This water heater may contain water at very high temperature and pressure. Wear protective clothing, safety glasses and gloves. Ensure the water in the tank and coil has cooled to room temperature before disconnecting fittings, piping or valves or opening the drain valve. Do not solely rely on the pressure and temperature gauges to determine the temperature and pressure of the water in the water heater.
- If the temperature and pressure relief valve on the appliance discharges periodically, this may be due to thermal expansion in a closed water supply system. Contact the water supplier or local plumbing inspector on how to correct this situation. Do not plug the temperature and pressure relief valve.
- Hydrogen Sulfide gas can be produced in a hot water system that has not been used for a long period of time (generally, two weeks or more). Hydrogen Sulfide gas is extremely flammable. To prevent the possibility of injury under these conditions, we recommend the hot water faucet to be open for several minutes at the kitchen sink before you use any electrical appliance which is connected to the hot water system. If hydrogen is present, there will probably be an unusual sound such as air escaping through the pipe as the hot water begins to flow. There should be no smoking or open flame near the faucet at the time it is opened.
- Verify proper operation after servicing.

6.2 ANNUAL SERVICE

The owner or user should have a qualified heating technician perform annual service as follows:

1. Water Piping: Check all domestic water and boiler water piping for signs of leakage at joints, valves, unions and other fittings.
2. Controls and Valves: Check function of controls and valves as per the control/valve manufacturer's instructions. If the circulator is oil-lubricated, follow the instructions on the circulator to oil it.
3. Flushing the tank:
 - When draining tank use caution as water will be hot.
 - Shut off power.
 - Shut off domestic water supply to tank. To relieve pressure in tank, open a hot water faucet.
 - Open drain valve. Allow water to flow until it runs clear or empties.
 - For chemical flushing, remove the relief valve and apply the chemical flushing technique as per the manufacturer's instructions.
 - Close drain valve.
 - Open domestic water inlet shut-off valve. Close hot water faucet after flow is established.
 - Resume power.
4. T & P Relief Valve: **DANGER:** Before operating T&P relief valve, make sure no person is near the T&P relief valve discharging piping. Hot discharge water can cause severe personal injury or substantial property damage. Check T&P relief valve is in accordance with manufacturer's



instructions. If short of such instructions, perform the following: move operating lever to open position for a few seconds and then move it back, allowing it to snap closed. If the relief valve continues to release water, close cold water inlet to water heater immediately. Follow “Flushing the tank” instructions to drain water and replace T & P relief valve.

5. Anode Rod: To prevent corrosion, each hot water tank is equipped with an anode rod usually accessible from the top of the tank. The anode dissolves slowly over a period of time sacrificing itself and preventing water ions from attacking the tank. Replacement of a depleted anode rod can extend the life of your hot water tank and should be checked annually. The anode rod should be replaced when the anode core becomes visible at any point along the rod. Before attempting to remove the anode, shut the cold water supply and drain enough water to empty the piping system. Hot discharge water can cause severe personal injury or substantial property damage. Flexible (link rods) anodes may be used if clearance from the top of the tank to the ceiling does not permit standard lengths. Contact your local plumbing wholesaler store or the manufacturer for replacement anode rods. **Failure to maintain an anode may result in premature failure of the tank and voids warranty.**

Anode rod inspection may need to be performed more frequently in areas with low pH value, as it will cause the anode to deplete more rapidly.

Teflon Tape reduces the effectiveness of the Magnesium Anode by acting as an insulator. An electrically conductive sealant should be used on the anode threads.

6.3 MONTHLY SERVICE

Visual Check: Visually check joints, valves and other fittings for leaks. Call a qualified service technician to repair any leaks found.

These instructions are for general guidance only; please contact a technician or plumber for required local codes and standard procedures.



Troubleshooting Guide **Section 7**

Problem	Possible Cause	Solution
No Hot Water	Tank control failure	<ul style="list-style-type: none"> • Check wiring and power supply • Replace control
	Aquastat not calling for heat	<ul style="list-style-type: none"> • Check wiring • Replace aquastat
	Air lock in domestic water loop	<ul style="list-style-type: none"> • Purge and bleed piping
	Circulator not operating	<ul style="list-style-type: none"> • Repair or replace circulator
	Zone valve not operating	<ul style="list-style-type: none"> • Check wiring and power supply / open manually to check • Replace zone valve
	Boiler not operating	<ul style="list-style-type: none"> • Boiler control too low • Check wiring • Check disconnect switch • Check fuse or circuit breaker • Check wiring and power supply
Insufficient Hot Water	Aquastat setting too low	<ul style="list-style-type: none"> • Adjust aquastat to higher setting
	Defective aquastat or improper calibration	<ul style="list-style-type: none"> • Replace aquastat
	Undersized water heater	<ul style="list-style-type: none"> • Install adequate water heater
	Undersized boiler with no priority to domestic hot water	<ul style="list-style-type: none"> • Rewire for priority / check sizing
Slow Hot Water Recovery	Undersized boiler with no priority to domestic hot water	<ul style="list-style-type: none"> • Rewire for priority / check sizing
	Inadequate boiler water flow	<ul style="list-style-type: none"> • Check circulator sizing • Ensure valve is open • Purge and bleed piping
	Circulator capacity too low	<ul style="list-style-type: none"> • Replace circulator with correct one
	Scale build-up in tank	<ul style="list-style-type: none"> • Chemical cleaning or repeated flushing
Water Too Hot	Aquastat setting too high	<ul style="list-style-type: none"> • Adjust aquastat to lower setting
	Aquastat continuously runs	<ul style="list-style-type: none"> • Check wiring • Replace aquastat
	Improper system piping and/or control	<ul style="list-style-type: none"> • Check piping and flow control valve
	Improper system wiring	<ul style="list-style-type: none"> • Check wiring
	Tempering (mixing) valve	<ul style="list-style-type: none"> • Read valve instructions or consult with manufacturer
Discharge From Relief Valve	Inlet cold water pressure too high	<ul style="list-style-type: none"> • Install pressure reducing valve
	Excessive water pressure when heating	<ul style="list-style-type: none"> • Install properly sized potable thermal expansion tank on cold water inlet
	Relief valve leaking	<ul style="list-style-type: none"> • Replace relief valve



NOTES

Section 8



Index	Section 9
--------------	------------------

Section		Page
	DIMENSIONS AND SPECIFICATIONS	2
1	PRE-INSTALLATION	3
1.1	RECEIVING	3
1.2	INSTALLATION CODES AND REQUIREMENTS	3
1.3	LOCATION	3
1.4	OPERATING RESTRICTIONS	4
1.5	WATER QUALITY	4
2	PIPING AND PLUMBING	5
2.1	BOILER SIDE PLUMBING	5
2.2	INSTALLATION DIAGRAMS	6
2.3	DOMESTIC SIDE PLUMBING	10
2.4	T&P RELIEF VALVE PLUMBING	10
2.5	WATER HAMMER	10
3	WIRING DIAGRAMS	12
4	STARTUP AND ADJUSTMENT	17
4.1	PRE-START UP CHECKLIST	17
4.2	STARTUP INSTRUCTIONS	17
5	WATER ADJUSTMENT	18
5.1	CONTROL/AQUASTAT	18
5.2	AQUASTAT TEMPERATURE	18
5.3	TEMPERATURE ADJUSTMENT	19
6	SERVICE AND MAINTENANCE	20
6.1	GENERAL OPERATION	20
6.2	ANNUAL SERVICE	20
6.3	MONTHLY SERVICE	21
7	TROUBLESHOOTING GUIDE	22
8	NOTES	23
9	INDEX	24