

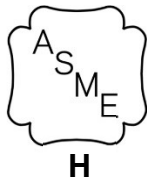

# INSTALLATION AND SERVICE MANUAL

## SG SERIES BOILERS

FOR MODELS SG-135-E TO SG-495-E

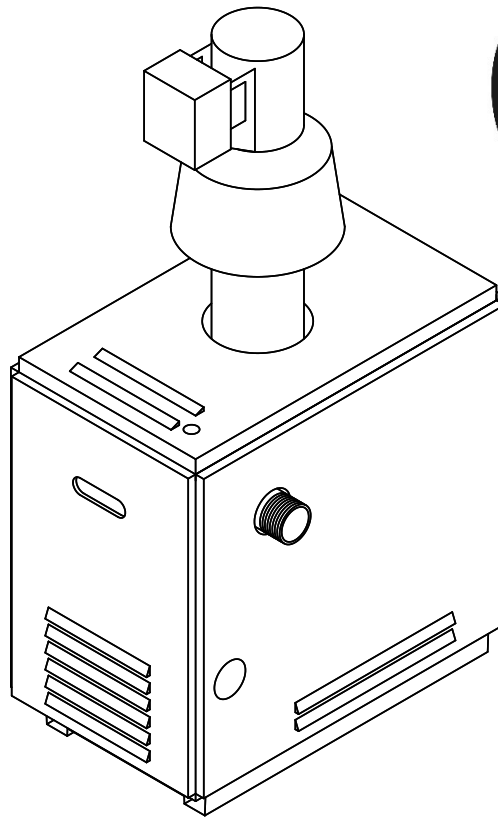

### WARNING

Improper installation, adjustment, alteration, service or maintenance can cause property damage, injury, or loss of life. Please carefully read this manual. For assistance or additional information, consult a qualified installer, service agency or the gas supplier.

Manufactured by

**Allied Technologies**

Division of E-Z-Rect Manufacturing Ltd.

Manufacturers of Gas and Electric Boilers, Stainless Steel Tanks, Heat Exchangers and Electric Boosters.  
94 Riverside Drive, North Vancouver, B.C. V7H 2M6 • Telephone (604) 929-1214 • www.alliedboilers.com

Branches: Calgary • Edmonton • Toronto • Denver



## Table of Contents

Section	Page
Dimensions and Specifications – For Models SG-135 to SG-270 .....	3
Dimensions and Specifications – For Models SG-315 to SG-495 .....	4
Boiler Water Flow Data .....	5
About Our Manuals .....	6
<b>1 Lighting Instructions.....</b>	<b>6</b>
1.1 Safety Instructions .....	6
1.2 Lighting Instructions .....	6
1.3 Lighting Instructions for Intermittent Electronic ignition with Combination Gas Valve .....	7
1.4 Lighting Instructions for Intermittent Electronic Ignition with Non-Combination Gas Valve .....	7
1.5 To Turn off Gas to the Boiler or Emergency Shut-Off.....	8
1.6 Controller Programming and Service Codes (SG-135 to SG-270) .....	8
1.7 BC-1 Controller (For 2 stage boilers only).....	13
<b>2 Installation Instructions.....</b>	<b>18</b>
2.1 Receiving.....	18
2.2 Installation Codes and Requirements .....	18
2.3 Location .....	18
2.4 Gas Service Piping.....	19
2.5 Air Supply for Combustion and Ventilation.....	19
2.6 Corrosive Atmospheres.....	20
2.7 Venting .....	20
2.8 Automatic Vent Damper (SG-135 to SG-270).....	21
2.9 Blocked Vent and Flame Roll-out Safety Switches (SG-135 to SG-270) .....	22
2.10 Boiler Piping System .....	22
2.11 Corrosion Prevention (Internal).....	22
2.12 System Operating Requirements .....	23
2.13 Water Quality.....	23
2.14 Pressure Relief Valve.....	23
2.15 Electrical Wiring.....	24
<b>3 Startup Instructions .....</b>	<b>24</b>
3.1 Pre-startup.....	24
3.2 Startup.....	24
3.3 Check Burner System .....	26
3.4 Aquastat Adjustment .....	26
3.5 Gas Manifold Pressure.....	26
3.6 Check Input & Orifices.....	27
3.7 Check for Draft Hood Spillage.....	28
3.8 Check of Controls.....	28
3.9 Check for Gas Leaks.....	28
3.10 Installer’s Checklist.....	29
<b>4 Service &amp; Maintenance Instructions .....</b>	<b>30</b>
4.1 Service & Maintenance Instructions .....	30
4.2 Cleaning Procedure.....	30
4.3 Service Checklist.....	31
4.4 Caution: Water Replenishment .....	32
4.5 Refractory Handling Procedure .....	32
<b>5 Replacement Parts .....</b>	<b>33</b>
<b>6 Wiring Diagrams .....</b>	<b>36</b>
<b>7 Troubleshooting Guide.....</b>	<b>44</b>
<b>8 Notes.....</b>	<b>46</b>



# SG SERIES BOILERS

## DIMENSIONS AND SPECIFICATIONS FOR MODELS SG-135 TO SG-270

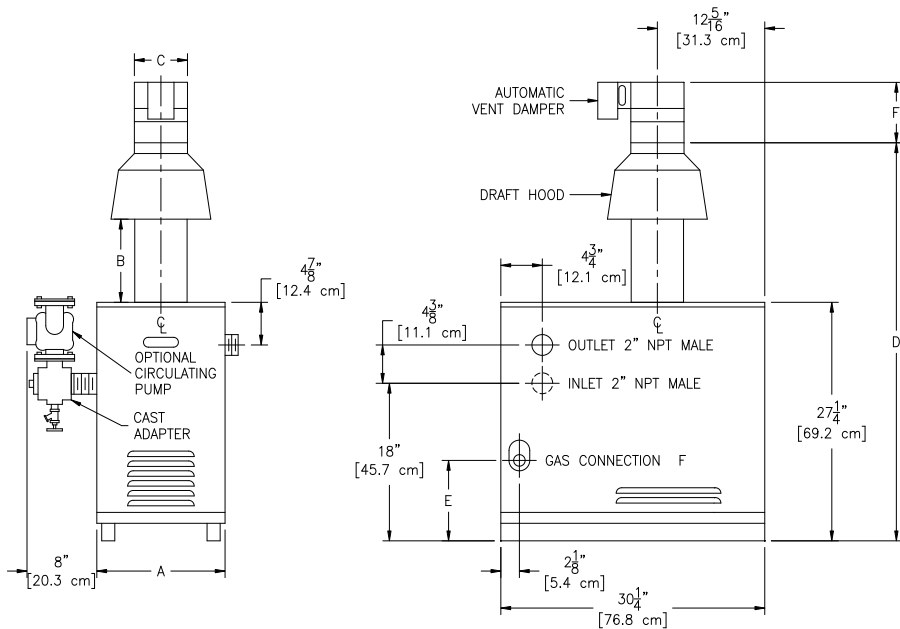

### Standard Model Includes:

- Integrated Boiler Controller
- Zone Control Board with Transformer
- Stainless Steel Burners
- Combination Gas Valve
- High Limit Sensor
- Temperature / Pressure Gauge
- A.S.M.E. Pressure Relief Valve
- Drain Valve
- Draft Hood
- Blocked Vent Safety Switch
- Flame Roll-out Safety Switch
- Automatic Vent Damper

### “PS” Packaged Models Include

#### Standard Model Parts plus:

- Circulating Pump
- Custom Cast Iron Pump Adapter
- Expansion Tank
- Air Purger
- Combination Fill / Regulator Valve
- Automatic Air Vent

Allow 24” (609 mm) minimum in front for servicing.

Minimum clearances to combustible material: Top 24” (610 mm), Sides 2” (51 mm), Rear 2” (51 mm), Flue 6” (153 mm)

APPROVED FOR COMBUSTIBLE FLOORS & CLOSET INSTALLATION.

The Super Hot product improvement program may result in changes to the design and/or specifications being made without notice.

MODEL NUMBER	INPUT*	OUTPUT**	NET AHRI RATING †	AFUE	DIM A	DIM B	DIM C	DIM D	DIM E	DIM F	GAS CONN. F	SHIPPING WEIGHT
	MBH	MBH	MBH	%	in.	in.	in.	in.	in.	in.	NPT	lb.
SG-135	135	115	100	85.0	14.7	9.5	6.0	45.3	9.8	4.5	1/2"	191
SG-180	180	153	133	85.0	17.7	9.5	6.0	45.3	9.8	4.5	1/2"	222
SG-225	225	191	166	85.0	20.7	9.5	7.0	46.5	9.8	6.5	3/4"	253
SG-270	270	229	199	85.0	23.7	9.5	8.0	47.6	9.8	7.5	3/4"	284

MODEL NUMBER	INPUT*	OUTPUT**	NET AHRI RATING †	AFUE	DIM A	DIM B	DIM C	DIM D	DIM E	DIM F	GAS CONN. F	SHIPPING WEIGHT
	kW	kW	kW	%	cm	cm	cm	cm	cm	cm	NPT	kg
SG-135	39.6	33.7	29.3	85.0	37.3	24.1	15.2	115	24.9	13.9	1/2"	87
SG-180	52.8	44.8	39.0	85.0	45.0	24.1	15.2	115	24.9	13.9	1/2"	101
SG-225	65.9	56.0	48.6	85.0	52.6	24.1	17.8	118	24.9	16.5	3/4"	115
SG-270	79.1	67.1	58.3	85.0	60.2	24.1	20.3	121	24.9	19.0	3/4"	129

\* For altitudes above 2,000 feet, refer to Section 3.6 to determine the appropriate Input de-rate or contact the factory.

\*\* Output based on Natural Gas models

† Based on piping and pickup allowance of 1.15.

### Options:

- Natural Gas add suffix "N" - Propane models add suffix "P"
- Electric Ignition add suffix "E"
- Add 45 pounds weight (20 kg) for packaged boilers - add suffix "PS"



# SG SERIES BOILERS

## DIMENSIONS AND SPECIFICATIONS FOR MODELS SG-315 TO SG-495

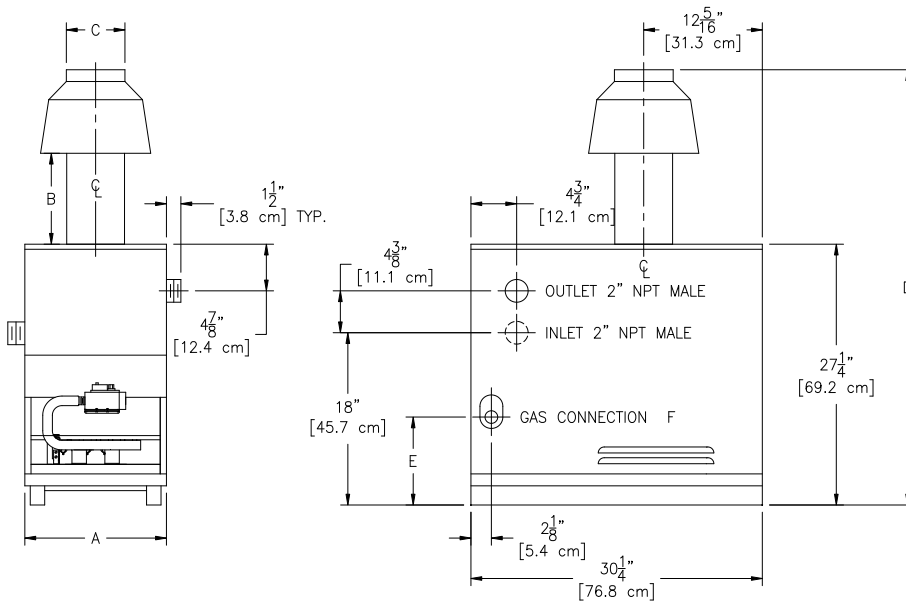

### Standard Model Includes:

- Electronic Ignition
- Stainless Steel Burners
- Combination / Non-Combination Gas Valve
- Redundant Gas Valve
- Operating Aquastat
- High Limit Aquastat
- Temperature / Pressure Gauge
- A.S.M.E. Pressure Relief Valve 30 psi
- Drain Valve
- Draft Hood
- Transformer
- Control Panel Enclosure

Allow 24" (610 mm) minimum in front for servicing.

Minimum clearances to combustible material: Top 24" (610 mm), Sides 2" (51 mm), Rear 2" (51 mm), Flue 6" (153 mm)

APPROVED FOR COMBUSTIBLE FLOORS & CLOSET INSTALLATION, do not install on carpeting.

The Super Hot product improvement program may result in changes to the design and / or specifications being made without notice.

MODEL NUMBER	INPUT*		OUTPUT			DIM A**		DIM B		DIM C		DIM D		DIM E		GAS CONN. F	SHIPPING WEIGHT	
	MBH	kW	MBH	kW	H.P.	in.	cm	in.	cm	in.	cm	in.	cm	in.	cm		NPT	lb.
SG-315	315	92.3	265	77.7	7.9	26.7	67.8	9.5	24.1	8.0	20.3	47.6	121	9.8	24.9	3/4"	307	140
SG-360	360	106	303	88.8	9.0	29.7	75.4	9.5	24.1	9.0	22.9	48.6	124	11.5	29.2	3/4"	336	153
SG-400	400	117	337	98.7	10.0	32.7	83.1	9.5	24.1	9.0	22.9	48.6	124	11.5	29.2	3/4"	368	167
SG-450	450	132	379	111	11.3	35.7	90.7	15.5	39.4	10.0	25.4	55.3	140	11.5	29.2	1"	395	180
SG-495	495	145	417	122	12.4	38.7	98.3	15.5	39.4	10.0	25.4	55.3	140	11.5	29.2	1"	424	193

\* For altitudes above 2,000 feet, refer to Section 3.6 to determine the appropriate Input de-rate or contact the factory.

\*\* Add 3" to dimension 'A' (1 1/2" to each side of boiler) to allow for 2" NPT water connections.

### Options:

- Natural Gas add suffix "N" - Propane models add suffix "P"
- Electric Ignition add suffix "E"
- High/Low fire add suffix "M" - Full Modulation add suffix "MOD"



**Boiler Water Flow Data**

NOTE: The boiler should be properly sized for its heating application and maintain an adequate water flow rate during operation. Significantly over sizing the boiler or decreasing boiler water flow rate will cause excessive stage cycling and may result in premature failure of components.

**Typical Water Flow versus Pressure Drop across Boiler**

Model Number	20°F ΔT		30°F ΔT	
	U.S. GPM	P.D. FT.	U.S. GPM	P.D. FT.
SG-135	11.5	2.8	7.7	1.2
SG-180	15.3	2.8	10.2	1.2
SG-225	19.1	2.8	12.8	1.2
SG-270	23.0	2.8	15.3	1.2
SG-315	26.5	3.2	17.7	1.3
SG-360	30.3	3.2	20.2	1.4
SG-400	33.7	3.3	22.5	1.4
SG-450	37.9	3.8	25.3	1.6
SG-495	41.7	4.0	27.8	1.8

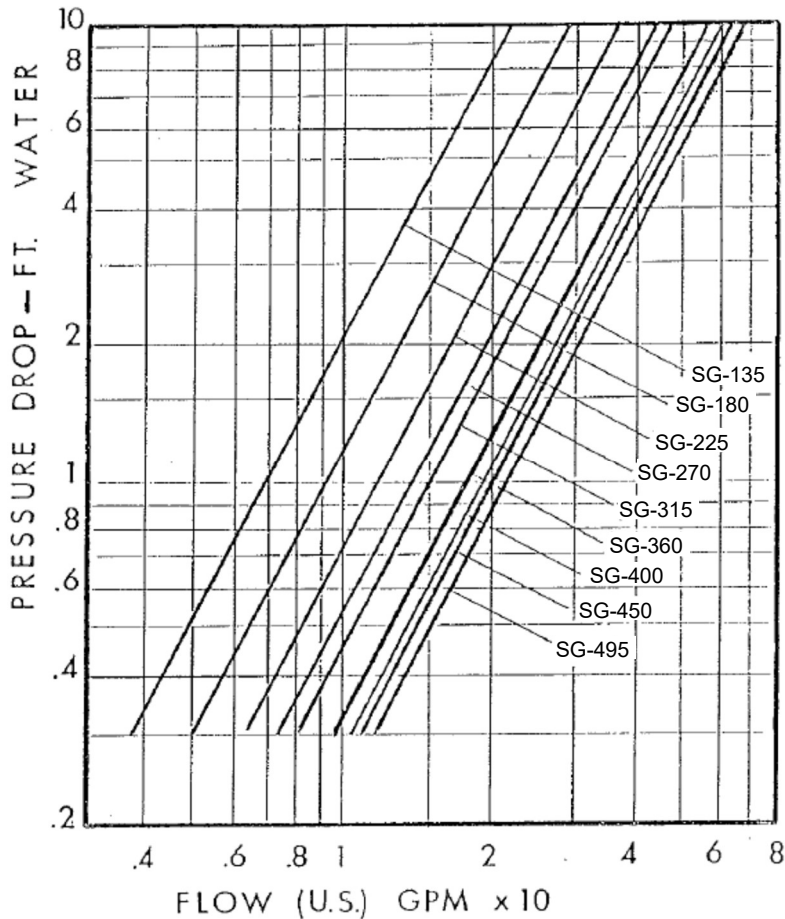

**SG Heat Exchanger Pressure Drop Graph**



**ABOUT OUR MANUALS**

Your *Super Hot* boiler has been provided with two manuals:

- *User's Information Manual* - This manual is intended for the **owner or user** of the boiler and provides information on routine operation and maintenance, and emergency shutdown.
- *Installation and Service Manual* - This manual must only be used by a **qualified heating installer, service technician or gas supplier**. Installation or service by anyone unqualified to do so may result in severe personal injury, death or substantial property damage.

Both manuals should be kept in the envelope provided and affixed adjacent to the boiler so that they are readily available for future reference.

<b>Lighting Instructions</b>	<b>Section 1</b>
------------------------------	------------------

**1.1 SAFETY INSTRUCTIONS**

**WARNING**

**If you do not follow these instructions exactly, a fire or explosion may result causing property damage, personal injury or loss of life.**

- |  |  |
|--|--|
| <p>A. BEFORE LIGHTING smell all around the boiler area for gas. Be sure to smell next to the floor because some gas is heavier than air and will settle on the floor.</p> <p>WHAT TO DO IF YOU SMELL GAS</p> <ul style="list-style-type: none"> <li>• Do not try to light any appliance.</li> <li>• Do not touch any electrical switch; do not use any phone in your building.</li> <li>• Immediately call your gas supplier from a neighbor's phone. Follow the gas supplier's instructions.</li> <li>• If you cannot reach your gas supplier, call the fire department.</li> </ul> | <p>B. Use only your hand to push in or turn the gas control knob. Never use tools. If the knob will not push in or turn by hand, don't try to repair it, call a qualified service technician. Force or attempted repair may result in a fire or explosion.</p> <p>C. Do not use this boiler if any part has been under water. Immediately call a qualified service technician to inspect the appliance and to replace any part of the control system and any gas control which has been under water.</p> |
|--|--|

**1.2 LIGHTING INSTRUCTIONS**

Determine the ignition system that applies from the list below and go to the applicable lighting instruction section.

- Intermittent electronic ignition with combination gas valve (*Section 1.3*)
- Intermittent electronic ignition with non-combination gas valve (*Section 1.4*)

*Note: A **combination gas valve** combines the operating and safety shut-off into one valve body.*

*A **non-combination gas valve** system utilizes separate valve bodies for operating and safety shut-off.*



### 1.3 LIGHTING INSTRUCTIONS FOR INTERMITTENT ELECTRONIC IGNITION WITH COMBINATION GAS VALVE.

1. This boiler is equipped with an ignition device which automatically lights the pilot. Do not try to light the pilot by hand. Ensure gas supply to the boiler is turned on.
2. STOP! Read the safety instructions in *Section 1.1*.
3. Set the room thermostat to lowest setting.
4. Turn off all electrical power to the appliance.
5. Remove control access panel if necessary.
6. Push in gas control knob slightly and turn clockwise ↻ to "OFF".

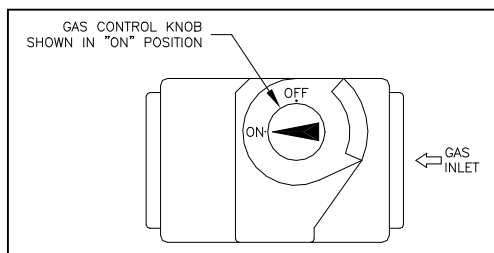

- NOTE: On some gas valves the knob cannot be turned to "OFF" or "ON" position unless knob is pushed in slightly. Do not force.
7. Wait five (5) minutes to clear out any gas. Then smell for gas, including near the floor. If you smell gas, STOP! Follow "A" in the safety instructions in *Section 1.1*. If you don't smell gas, go to the next step.
  8. Turn gas control knob counterclockwise ↻ to "ON".
  9. Replace control access panel if necessary.
  10. Turn on all electrical power to the boiler.
  11. Set room thermostat to desired setting.
  12. If the appliance will not operate, follow the instructions "To Turn Off Gas To Boiler" in *Section 1.6* and call your service technician or gas supplier.

**To turn off gas to boiler or emergency shut-off**  
Follow *Section 1.5*.

### 1.4 LIGHTING INSTRUCTIONS FOR INTERMITTENT ELECTRONIC IGNITION WITH NON-COMBINATION GAS VALVE.

This boiler is equipped with an ignition device, which automatically lights the pilot. Do not try to light the pilot by hand. Before turning on the electrical power switch, be sure all gas supply lines are purged of air and power supply to control is the correct voltage.

If the pilot or main burners are not lit or the control system is locked-out due to flame failure, close the main and pilot gas shut-off valves and call your service technician or gas supplier. If you smell gas, STOP! Follow "A" in the safety instructions in *Section 1.1*.

#### **Check Control Operation**

1. STOP! Read the safety instructions in *Section 1.1*.
2. For 100% shut off check, close main and pilot manual gas shut off valves, turn off all electric power to the boiler and wait for five minutes to clear out any gas.
3. Then smell for gas, including near the floor. If you smell gas, STOP! Follow safety instructions in *Section 1.1*. If you don't smell gas, go to the next step.
4. Set the thermostat above room temperature and turn on all electric power to the boiler to energize the electronic ignition and pilot valve. After a few seconds, control system should "lockout" and all functions are off.
5. To take the control system out of "lockout" either press the reset button or interrupt power to the boiler, depending on the boiler controller. Some controllers will retry ignition automatically after 5 minutes lockout.

#### **Start System**

1. Turn on the main and pilot manual gas shut-off valves.
2. Set thermostat above room temperature and turn on all electrical power to the boiler.
3. Once the pilot flame is proven, the controller opens the main burner gas valves. The pilot flame will ignite the gas as it exits the main burner ports.
4. Set thermostat to the desired setting to put system back in service.

#### **Relight Operation**

Five minutes complete shut off period is required before attempting to relight the boiler. To relight the boiler, follow the Start System procedure (above).

**To turn off gas to boiler or emergency shut-off**  
Follow *Section 1.5*



**1.5 TO TURN OFF GAS TO THE BOILER OR EMERGENCY SHUT-OFF**

**WARNING**

Should the boiler overheat, or the gas supply fail to shut off, do not turn off or disconnect the electrical supply to the circulating pump. Instead, shut off the gas supply at a location external to the boiler.

1. Set the thermostat to the lowest setting.
2. Turn all electrical power to the boiler off.
3. Remove control access panel on the boiler if necessary.
4. For **combination valve**: Push in gas control knob slightly and turn clockwise ↻ to "OFF". Do not force it.  
 For **non-combination valve**: Close the main and pilot manual gas shut off valves. The valve is "OFF" when handle is perpendicular to the direction of gas flow.
5. Replace control access panel if necessary.

**1.6 CONTROLLER PROGRAMMING AND SERVICE CODES (SG-135 to SG-270)**

**2012 NRCAN and DOE Compliance and Operation**

Operation of this control may delay the burner operation while the residual heat is circulated out of the boiler.

The integrated boiler control module provides ignition sequence, flame monitoring and safety shutoff for intermittent pilot spark ignition. It also provides limit rated water temperature control for with two separate sensors in one casing (3-wire).

The control is located on the front panel inside the boiler. The control display, along with Up ▲, Down ▼, and "I" keys may be used to view boiler operating status and program parameters (Figure 1).

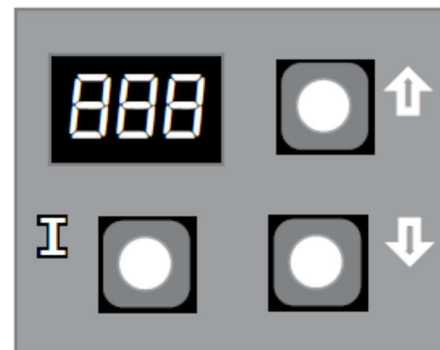

**Figure 1 Control Display**

**1.6.1 RUN MODE**

In the RUN mode, status items and parameters are viewable.

To read settings, press and release the "I" key to find the parameter of interest. Each setting will alternately flash between the relevant display code listed in the Table 1 and its corresponding value.

For example, press and release "I" key until "HL\_" setpoint is displayed, it will then flash a three-digit number, i.e., 220, followed by °F (or °C). This indicates that the boiler water temperature of 220 °F is set. Other operating parameters display the settings in a similar fashion.

**Table 1 - Run Mode Parameters**

Text	Description	Display
STA	Status (see status numbers)	StA
BT	Boiler temperature	bT
SP	Operating setpoint	SP
HL	High limit setpoint	HL
HdF	Differential set-point	HdF
FLA	Flame current	FLA
RUN	Run time hours	rUn
CYC	Boiler cycles	[Y]
ERR	Error (see error numbers)	Err





## 1.6.2 INSTALLER MODE

To enter the adjustment mode:

1. Press with Up ▲, Down ▼, and “I” keys (see Figure 1) simultaneously for three seconds.
2. Press and release the “I” key until the parameter (listed in the Table 2) requiring adjustment is displayed.
3. Press with Up ▲ or Down ▼ key until the parameter has reached the desired value.
4. After 60 seconds without any key inputs, the control will automatically return to the RUN Mode.

**Table 2 - Installer Mode Options**

3-Digit 7-Segment Display			Default	Range	Description
1 <sup>st</sup> Screen	2 <sup>nd</sup> Screen (setting value)	3 <sup>rd</sup> Screen			
<i>HL</i> _	<high limit>	°F or °C	180 °F	130 to 220 °F	Adjust high limit setting
<i>HdF</i>	<high limit differential>	°F or °C	15 °F	10 to 30 °F	Adjust high limit differential
<i>Or</i> _	<pump overrun time>	Sec	60 sec	0 to 120 seconds	Pump post-purge time
<i>oLH</i>	<ODR maximal temp.>	°F or °C	55 °F	40 to 70 °F	Maximal outdoor temperature
<i>oLl</i>	<ODR minimal temp.>	°F or °C	0 °F	-40 to 40 °F	Minimal outdoor temperature
<i>bLl</i>	<minimal water temp.>	°F or °C	140 °F	130 to 150 °F	Minimal boiler temperature
<i>tPL</i>	<minimal boiler temp.>	°F or °C	140 °F	OFF, 120 to 160 °F	Thermal purging minimal temperature (parameter is available only if outdoor temperature is invalid)
<i>tPt</i>	<maximal delay>	Min	2	1 to 10 minutes	Maximal thermal purge time (parameter is available only if outdoor temperature is invalid)
<i>rSt</i>	On or OFF		N/A	N/A	Reset lockout
<i>F-[]</i>	°F or °C		°F	°F or °C	Select degrees °F or °C mode



## 1.6.3 OPERATING CHECKOUT

After adjusting parameters, put the boiler into operation and observe operation through at least one complete cycle to make sure that the controller operates properly. See controller troubleshooting section to assist in determining boiler operation.

The sensor should fit snugly and should touch the bottom of the well for best temperature response. The sensor is held inside the well using the well clip.

## 1.6.4 THERMAL PURGE

The intent of thermal purge is to ensure usable residual heat in the boiler is circulated until it is sufficiently depleted from the system before the burner is allowed to fire. To that end, on a call for heat, the burner remains off while the circulator runs until the boiler temperature drops to the thermal purge temperature limit or the time delay is exceeded. Both of these parameters are adjustable. When the boiler temperature falls below the thermal purge temperature limit or the time delay expires, the burner is allowed to fire.

In addition to the thermal purge temperature and thermal purge time delay parameters, two other conditions release the integrated boiler controller from thermal purge and allow the burner to run in order to maintain comfort in the space:

- The boiler temperature has dropped 10 °F from the boiler water temperature measured at the beginning of the call for heat.
- Boiler temperature is cooling at a rate greater than 5 °F/minute while the circulator is running.

## 1.6.5 OPERATING STATE CODES AND TROUBLESHOOTING

When there is a problem during a call for heat or boiler operation, the controller provides specific information to help resolve the issue quickly. If the controller is displaying “SEt” by a number, use the state code definitions in the Table 3 to determine the problem and possible causes.

## 1.6.6 CONTROLLER MOUNTING

The controller has four tabs which align with four slots in the control panel. To remove the controller, press and hold in the bottom two tabs while simultaneously rotating the controller about 45 degrees to unhook the top two tabs.

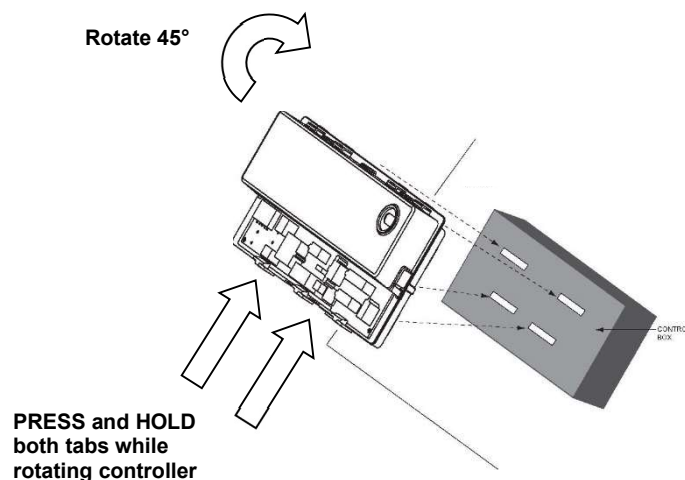



Table 3 - State Codes

Display Code	State	Specific Description
<b>Operation Sequence</b>		
5LR ↔ 1	Idle/Standby	The boiler is in standby - no call for heat.
	Run circulator	Heat request present but boiler water temperature sufficiently high to run circulator pump only (no ignition sequence).
<b>Thermostat Calls For Heat</b>		
5LR ↔ 17	Self Test	Hardware self check, check of connected periphery, it is performed at start up, in the beginning of the heat cycle and in the "Wait For recovery" state.
	Wait for recovery	There is an external error and the control is waiting to recover, no lockout.
<b>Circulator output energizes</b>		
5LR ↔ 2	Wait for end switch to open	The control is waiting for the end switch of the vent damper to open at the beginning of a heat cycle. If the end switch doesn't open in 60 seconds, the control goes to error code Err 2.
5LR ↔ 3	Wait for end switch to close	The control is waiting for the end switch of venting damper to close at the beginning of a cycle. If the end switch doesn't close within 60 seconds, the control goes to error code Err 29.
5LR ↔ 4	Pump pre-purge/ thermal purge	System is purging before ignition trial-safety relay diagnostics followed safety relay switch-on during last 2 seconds this state.
5LR ↔ 6	Spark, ignition activation	System is sparking permanently 13 seconds whilst pilot gas valve relay is turned on.
5LR ↔ 7	Prove flame	System is proving flame signal, typically 2 seconds.
5LR ↔ 8	Running	System is in running mode, flame signal must be present.
<b>Call For Heat Ends</b>		
5LR ↔ 9	Pump post-purge	System is purging at the end of a call for heat.
<b>Vent Damper Operation</b>		
5LR ↔ 18	Wait for vent damper to open	Damper actuator is energized and the system waits for damper to close.
5LR ↔ 19	Wait for vent damper to close	Damper actuator is de-energized and the system waits for damper to open.
5LR ↔ 20	Wait for vent damper to open - failed closed	Damper actuator is energized, system waits for damper to open, but the damper is stuck in closed position (damper end switch is open).
5LR ↔ 21	Wait for vent damper to close - failed open	Damper actuator is de-energized, system waits for damper to close, but the damper is stuck in open position (damper end switch is closed).
<b>Troubleshooting/Diagnostics</b>		
5LR ↔ 10	Inter-purge (retry/recycle delay)	If the control loses flame signal during state code 7 or 8, or flame is not detected during state code 6 to 8, it will recycle through the 30 seconds purge time and last 2 seconds part of pre-purge time.
5LR ↔ 15	Wait for limit to close	There may be a call for heat from the thermostat, but the limit switch is open.
5LR ↔ 16	Flame out of sequence – before trial	Flame signal sensed before trial for ignition.
	Flame out of sequence – after trial	Flame out of sequence during post-purge.
	Wait for flame loss	Flame signal still present when not expected.



If the controller is displaying “Err” followed by a number, use the error code definitions in the Table 4 to determine the problem and possible causes.

**Table 4 - Error Codes**

Display	State	Solution
Err ↔ 2	End switch of venting damper failed to open	The end switch of venting damper has not opened at the beginning of the heat cycle. The end switch contacts are stuck closed. The control is not in lockout. Check the venting damper and replace it if necessary.
Err ↔ 4	Low flame current	Check pilot assembly and replace it if necessary.
Err ↔ 6	Flame sensed out of normal sequence	Flame sensed out of normal sequence (before opening gas valve or after closing gas valve).
Err ↔ 18	Gas valve relays welded 5 consecutive soft lockouts	A manual reset is required.
Err ↔ 23	Flame sensed during pre-purge	Flame sensed during pre-purge (before gas valve signaled opened).
Err ↔ 24	Flame sensed during post-purge	Flame sensed during post-purge (before gas valve signaled closed).
Err ↔ 29	End switch of venting damper failed to close	The end switch contacts stuck open. Waiting time for pressure switch to close expired. The control is not in lockout. Check the venting damper and replace it if necessary.
Err ↔ 32	Sensor error	Temperature sensor or interface failure (open or short connection, increased connection resistance, dual sensor mismatch) or failure of A/D conversion (invalid offset or gain, too many failures during A/D conversion).
Err ↔ 55	End switch error	Atmospheric Damper End Switch failed to close (end switch contacts stuck open).
Err ↔ 56	End switch error	Atmospheric Damper End Switch failed to open (end switch contacts stuck closed).
Err ↔ 57	Flame rod shorted to burner ground	Check and adjust or replace if necessary.
Err ↔ 58	AC line frequency error	AC signal is too noisy or frequency is incorrect.
Err ↔ 59	Line voltage error	AC voltage out of specification high or low.
Err ↔ 60	Thermostat input higher than threshold	Check thermostat wiring and replace it if necessary.
Err ↔ 61	Line voltage unstable	Possibly too many heavy loads switching on and off cause erratic supply voltage.
Err ↔ 62	Soft lockout – Failure to establish flame signal	Maximum number of retries exceeded. System is shutdown and will re-start following an enforced delay.
Err ↔ 63	Soft lockout – Loss of flame signal	Maximum number of recycles exceeded. Caused by the pilot burner losing flame during running mode, “SERR”. After a 10 second delay, control will attempt to light the burner again (recycle). If the burner loses flame during the next six recycles, control progresses to soft lockout (Err 63).
Err ↔ 64	Soft lockout	Internal failure (Electronics failure). Caused by general electronics failure such as relay open or shorted contacts, flame sensing circuit error, or A to D error.
Err ↔ 65	Over temperature error	Sensor measured temperature in excess of ECO limit (230 °F).



## 1.7 BC-1 CONTROLLER (FOR 2 STAGE BOILERS ONLY)

### WARNING

**For boilers equipped with the BC-1 Controller, read all instructions in this manual and the *BC-1 Controller Manual* before placing the boiler in operation or making adjustments to the controller. Adjustments must be made by a qualified heating technician.**

The BC-1 controller is supplied as standard option with two stage boilers for models SG-315 and larger. It is not supplied with boilers equipped with a full modulating gas valve. For convenience, the BC-1 controller is factory wired to terminal block TB4 and ready for field wiring connections. The field wiring to TB4 is determined based on the operating mode selected (i.e. mode 1 to 6), the heating application and the piping arrangement (i.e. parallel or primary/secondary). Refer to Figure 2 for the wiring diagram for each mode. For important instructions regarding programming and operation of the BC-1 controller, refer to the *BC-1 Controller Manual* included with your boiler.

#### Power Outputs from BC-1:

**Boiler Stage** outputs from 15-STG1 and 17-STG2 terminals from the BC-1 are 24 Vac, 60 Hz (when factory wired).

**Alarm** output from 23-ALARM terminal from the BC-1 is 24Vac, 60Hz, 0.45A maximum (when factory wired). Alarm is wired to terminal block TB4, terminals AL&AL.

#### Signal Inputs (Do not apply external power):

The following signal inputs are located on terminal block TB4:

- HT&R:** Room thermostat or zone valve end switch, 24Vac switching input, closed is activation.
- ST&R:** Setpoint DHW aquastat, 24Vac switching input, closed is activation.
- FS&FS:** Flow switch, 24Vac switching input, closed is activation.

#### Thermistor Sensors:

- BO&CM:** Boiler outlet sensor
- BI&CM:** Boiler inlet sensor
- OS&CM:** Outdoor sensor
- SD&CM:** Supply / DHW sensor

#### BC-1 Controller Mounting

The BC-1 controller mounts on separate bracket on the control panel using a sheet metal screw at the top center. To remove the controller: 1.) remove the front casing panel, 2.) pull off the black top cover of the controller, 3.) unscrew the sheet metal screw, 4.) lift the controller slightly out of the rectangular cutout in the mounting bracket, 5.) pull off the Molex connector while simultaneously holding down the tab on the left side.



Figure 2 – BC-1 Controller



Field wiring to terminal block TB4

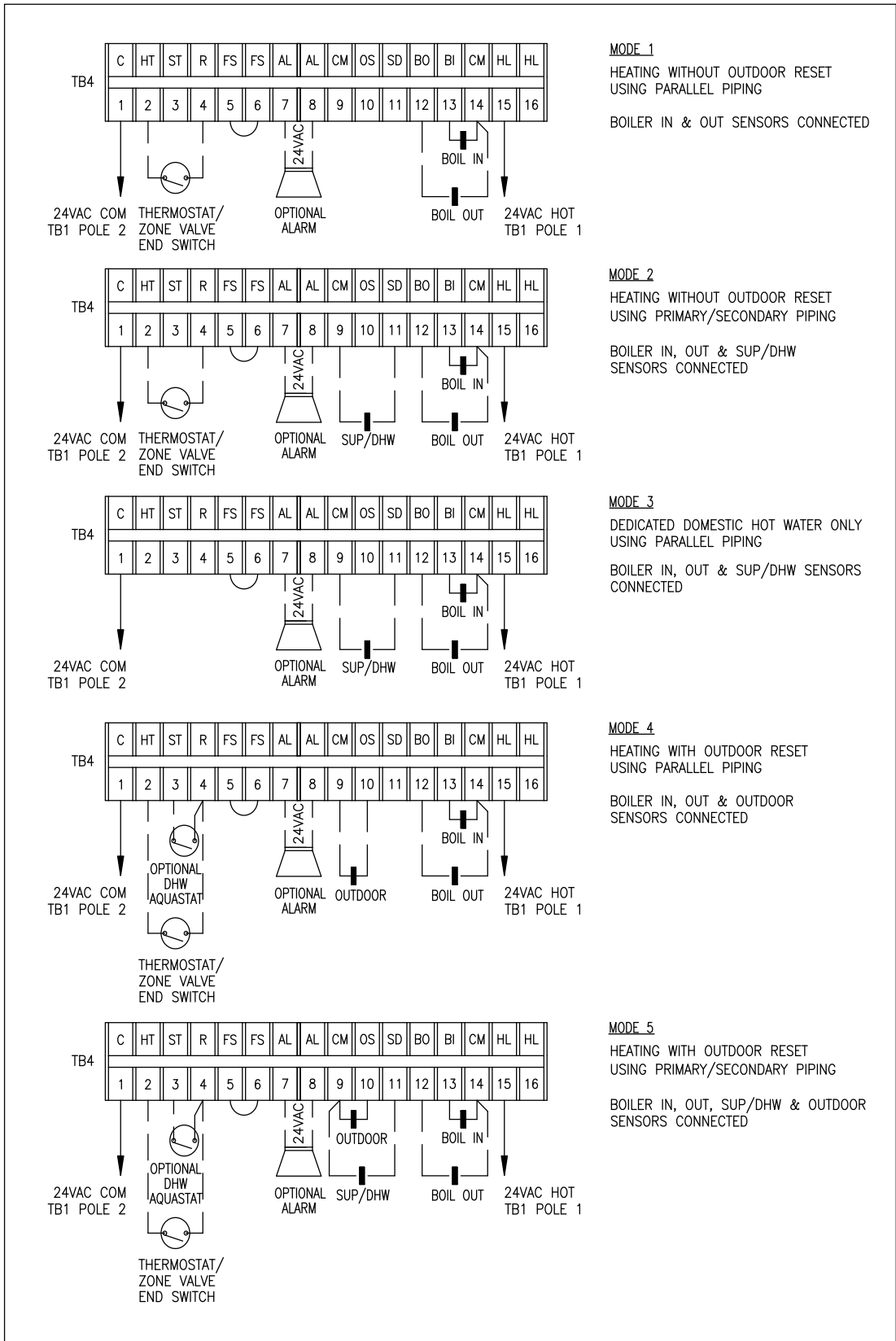

Figure 3 – Field wiring to terminal block TB4



**Electrical Connections**

**For all electrical connections:** Strip wire ends and insert into the terminal block. Tighten terminal screw clamps to securely hold the wire.

**CAUTION - Risk of damage to the controller - Do not apply power to any connections on terminal block TB4. 24 Vac has been factory wired to terminals C-1 and HL-15.**

Terminal Block	Connections	Name	Description / Comments
TB4	<b>BO &amp; CM</b>	Boiler Outlet Sensor	Connect boiler outlet water temperature sensor to terminals BO and CM (common). The Boiler Outlet Sensor must be attached using a cable tie to the boiler outlet pipe.
	<b>BI &amp; CM</b>	Boiler Inlet Sensor	Connect inlet water temperature sensor to terminals BI and CM (common). The Boiler Inlet Sensor must be attached using a cable tie to the boiler inlet pipe.
	<b>OS &amp; CM</b>	Outdoor Sensor	Optional Outdoor Sensor (for Mode 4 and 5 only): Connect Outdoor Sensor 070 to terminals OS and CM (common). The Outdoor Sensor is installed on an exterior wall, typically facing North, and above the snow line. It should be shielded from effects of heat or cold to prevent false outdoor temperature readings. Avoid direct sunlight, exhaust fans, appliance vents, and excessive moisture.
	<b>SD &amp; CM</b>	Supply/DHW Sensor	Optional (for Modes 2, 3, and 5 only). Connect a Supply or DHW Sensor 071 to terminals SD and CM (common). The Supply/DHW sensor is inserted into a thermowell on the DHW tank or attached using a cable tie to the supply pipe.
	<b>AL &amp; AL</b>	Alarm	Optional. The alarm contacts are a powered output, do not apply power. Connect an alarm (beeper, light, or relay) with a rating of 24 Vac and maximum 0.45 A to terminals AL and AL.
	<b>FS &amp; FS</b>	Flow Switch	Not used. Leave Jumper 5-6 on TB4. For convenience, the Flow Switch terminals have been relocated to terminal block TB2, poles T1 & S. Do not apply power.
	<b>ST &amp; R</b>	Setpoint DHW Demand	Optional Domestic Hot Water Aquastat (for Modes 4 and 5 only): Connect domestic hot water aquastat to terminals ST and R. Closed is activation. Do not apply power.
	<b>HT &amp; R</b>	Heat Demand	Connect Thermostat or Zone Valve End Switch to terminals HT and R. Closed is activation. Do not apply power.



## 1.7.1 BC-1 CONTROLLER OPERATION

When the controller is powered, the controller enters the operating mode if there are no sensors or high limit errors present. The user should select one of the following modes from the controller adjust menu:

**Mode 1 - Setpoint operation using parallel piping:** Operates boiler stages to maintain fixed temperature at boiler outlet sensor when a heat demand is present.

**Mode 2 - Setpoint operation using primary/secondary piping:** Operates boiler stages to maintain fixed temperature at boiler supply sensor when a heat demand is present.

**Mode 3 - Dedicated DHW Generation:** Operates boiler stages to maintain fixed temperature at the boiler outlet sensor when an internal demand for DHW is generated based on the DHW sensor. An indirect hot water tank must be used to isolate the boiler from an open system.

**Mode 4 - Outdoor reset with reset override using parallel piping:** Operates stages to maintain an outdoor reset temperature at the boiler outlet sensor. When there is a call for “reset override” from the DHW aquastat (i.e. ST&R is closed), the control operates the stages to maintain a setpoint temperature at the boiler outlet sensor. If both heat demand and setpoint DHW demand are present at the same time, the controller targets the higher of the two requirements.

**Mode 5 - Outdoor reset with reset override using primary/secondary piping:** Operates stages to maintain an outdoor reset temperature at the boiler supply sensor. When there is a call for “reset override” from the DHW aquastat (i.e. ST&R is closed), the control operates the stages to maintain a setpoint temperature at the boiler supply sensor. If both heat demand and setpoint DHW demand are present at the same time, the controller targets the higher of the two requirements.

**Mode 6 – External boiler control:** It is not necessary to use Mode 6 since Direct Digital Control (DDC) terminals have been provided on terminal block TB1. The DDC terminals may be used for connecting a boiler or multiple boilers to an external boiler control or an energy management system (EMS). See boiler wiring diagram for connection details.

When there is a heat demand or DHW demand the controller will switch on the system pump. If the sensor is not satisfied, the controller will switch stages on, in sequence, based on PID logic (proportional, integral, derivative). The controller continuously monitors the sensors and examines the difference between the target temperature and the sensor temperature. Depending on the difference in temperature (proportional), the time (integral), and how fast or slow the temperature is changing (derivative), it will determine when to switch a stage on or off. This feature prevents "short cycling", which can quickly wear out components and cause rapid temperature fluctuations.

The heating routine will operate until the water temperature reaches the user-defined temperature setting. Once reached, the control will automatically cycle the stage(s) of the boiler on or off, as necessary, to maintain the supply water temperature. The required number of stages which are activated is determined by the controller. After the call for heat has been satisfied, the stage(s) of the boiler will switch off, in sequence, followed by the pump.

## 1.7.2 RESET OVERRIDE

### WARNING

**If both Heat Demand and Setpoint DHW Demand are present at the same time, the controller targets the higher temperature of the two requirements. This may result in higher than intended water temperatures in either space heating loop or domestic hot water (DHW) heating loop. Use pipe rated for use at the highest possible water temperature.**

The BC-1 Controller has one pump relay which is normally open and will close (i.e. pump energized) when either a Heat Demand or Setpoint DHW Demand is present. When using Reset Override, a **switching external pump relay** (e.g. Tekmar Relay 003) should be utilized to stop hot water flow to the space heating loop (e.g. radiant in-floor) and redirect it to the DHW heating loop during a Setpoint DHW Demand. See Figure 4 and Figure 5.





MODE 4 ONLY

(Outdoor reset and reset override)

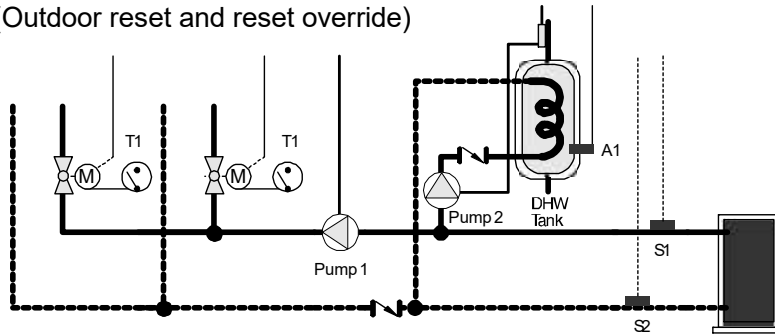

S1 = Boiler Outlet Sensor 071  
 S2 = Boiler Inlet Sensor 071  
 Pump1 = Boiler Pump  
 Pump2 = DHW Pump  
 A1 = DHW Aquastat  
 T1 = Thermostat

Figure 4 – Typical piping diagram in Mode 4

**Sequence of Operation**

**Thermostat (T1) closed** - Thermostat creates a Heat Demand resulting in a boiler target based on the outdoor reset settings. The boiler pump (Pump1) operates.

**DHW Aquastat (A1) closed** - DHW Aquastat creates Setpoint DHW Demand and activates external pump relay. The external pump relay causes the following actions:

- 1) Power for the boiler pump (Pump1) is broken. Pump1 does not operate.
- 2) Power for the DHW pump (Pump2) is made. Pump2 operates.
- 3) Setpoint DHW Demand creates a boiler target based on the higher requirement of the outdoor reset and reset override setting.

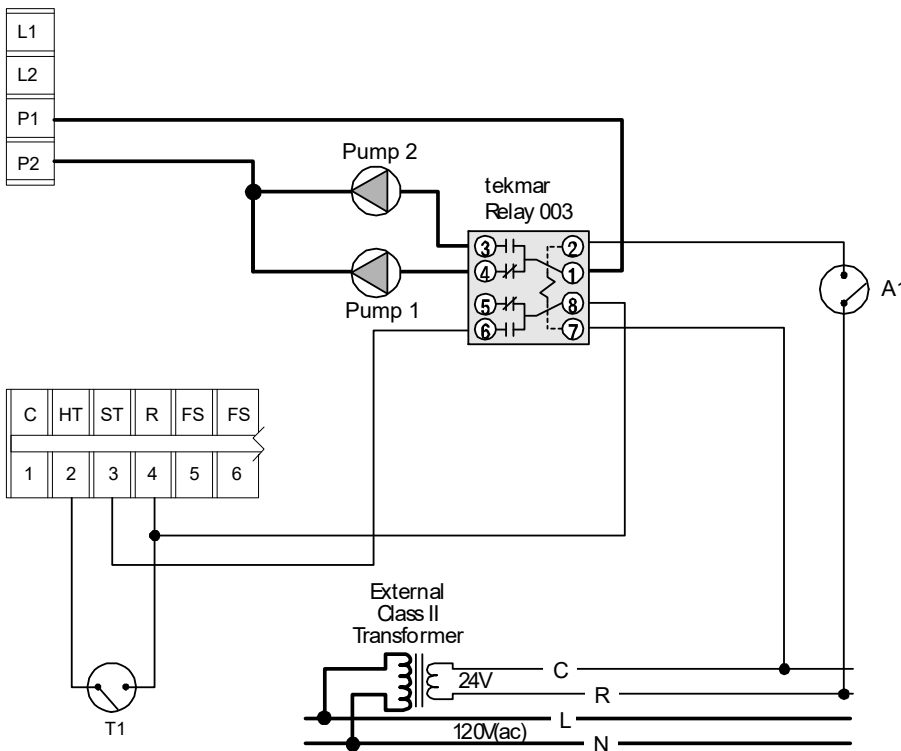

Figure 5 – Wiring diagram illustrating use of an External Relay to control pump operation



**Installation Instructions**

**Section 2**

**2.1 RECEIVING**

**INSPECT SHIPMENT FOR POSSIBLE DAMAGE.** All goods are carefully manufactured, inspected, checked and packed by experienced workers. The manufacturer's responsibility ceases upon delivery of goods to the carrier in good condition. Any claims for damage, shortage in shipment or non-delivery must be filed immediately against the carrier by the consignee.

Use care when receiving and unpacking the boiler. Dropping the boiler may cause damage and prevent safe and proper operation.

**2.2 INSTALLATION CODES AND REQUIREMENTS**

All applicable national, provincial/state, and local codes, laws, regulations, and ordinances must be followed. They expand on and take precedence over any recommendations in this booklet. Authorities having jurisdiction shall be consulted before installations are made.

In **Canada**, the installation must conform to the requirements of the authority having jurisdiction or, in the absence of such requirements, to the *CAN/CSA B149 Installation Codes* (current edition). All electrical wiring must be in accordance with the *Canadian Electrical Code, CSA C22.1 Part 1* (current edition) and applicable local codes.

In the **United States of America**, the installation must conform to the requirements of the authority having jurisdiction or, in the absence of such requirements, to the *National Fuel Gas Code, ANSI Z223.1* (current edition). All electrical wiring must be in accordance with the *National Electrical Code, ANSI/NFPA 70* (current edition) and applicable local codes.

Where required by the authority having jurisdiction, follow the *Standard for Controls and Safety Devices for Automatically Fired Boilers, ANSI/ASME CSD-1* (current edition).

**2.3 LOCATION**

**DANGER – RISK OF EXPLOSION**

Do not use or store gasoline or other flammable fuels or chemicals which have flammable vapors near the boiler. The vapors may be ignited by the heat or electronic components of the boiler.

**WARNING**

The boiler should be located in an area where water leakage of the boiler or its connections will not result in damage to the area adjacent to the appliance or to lower floors of the structure. When such locations cannot be avoided, a suitable drain pan must be installed under the appliance and the drain pan must be connected to a drain of adequate capacity.

Failure to comply with the above could result in severe personal injury, death or substantial property damage.

**CAUTION**

This boiler must be installed such that any electronic components are protected from water (dripping, spraying, rain, etc.) during appliance operation and service.



SG boilers are intended for indoor installation only. Observe the following minimum clearances from the boiler to combustible materials:

Minimum Clearances to Combustible Materials								
Model	Sides		Rear		Top		Front (service)	
	in.	mm	in.	mm	in.	mm	in.	mm
SG	2	51	2	51	24	610	24	610

- Minimum clearance from the boiler front to combustible materials is 6" (153 mm); however, a front clearance of 24" (609 mm) is recommended for servicing.
- Maintain a clearance of 6" (152 mm) from draft hood and the flue pipe in any direction.
- Allow ample space for boiler inlet and outlet connections, and gas connection.
- Boiler must be installed on a stable and level foundation.
- SG Series boilers can be installed on a combustible floor but must not be installed directly on carpeting.
- **A hot water boiler installed above radiation level must be provided with a low water cutoff device at the time of boiler installation.**

## 2.4 GAS SERVICE PIPING

The boiler and its gas connection must be leak tested before placing the boiler in operation. The gas controls furnished are suitable for a maximum operating gas pressure of 1/2 psi (14 inches water column).

The boiler and its individual shutoff valve must be disconnected from the gas supply piping system during any pressure testing of that system at test pressures in excess of 1/2 psig (14 inches water column).

The boiler must be isolated from the gas supply piping system by closing its individual manual shutoff valve during any pressure testing at test pressures equal to or less than 1/2 psig (14 inches water column).

A manual main shut-off valve should be installed in the gas line outside the boiler jacket and as required in *Section 2.2*. The valve should be readily accessible for turning on and off.

A drip pocket or sediment trap should be installed in the gas supply line upstream of the gas controls and as close to the boiler as possible (example shown in Figure 8 in *Section 5*).

Some of the pressure regulators or pressure regulating sections of gas valves are provided with an integral vent limiter and threaded connection. A bleed or gas relief line should be connected to it and piped to the outdoors.

The pipe compound used should be resistant to the action of liquefied petroleum gases. Check for gas leaks in piping before placing the boiler in operation by using a soap and water solution. **DO NOT USE AN OPEN FLAME.**

### **INSTALLER MUST IDENTIFY EMERGENCY SHUT-OFF DEVICES.**

All piping and fittings must be installed as per codes in *Section 2.2*.

## 2.5 AIR SUPPLY FOR COMBUSTION AND VENTILATION

A sufficient air supply **MUST** be provided to this boiler. Air openings to the boiler room provide the air for combustion, flue gas dilution and ventilation and are always required, regardless whether the air is taken from inside or outside. The air opening size and location (as well as other air supply and venting considerations) must conform to *Section 2.2*.

The boiler room must never be under a negative pressure. Always provide air openings sized not only to the dimensions required for the total input of all fuel-fired appliances in the boiler space, but also to handle the air movement rate of any **exhaust fans** or **air movers** using air from the building or space.

The venting terminations must always be kept clear of obstructions (i.e. snow, ice, etc.). Louvers and grilles used in the air supply and ventilation system should be kept clear of any dust, dirt, or debris which will block proper air flow.



## 2.6 CORROSIVE ATMOSPHERES

If a gas boiler is to be installed near a corrosive or potentially corrosive air supply, the boiler should be isolated from it and outside air should be supplied as recommended in *Section 2.5*.

Chemical vapors from products containing **chlorine** or **fluorine** must be avoided. Even though these chemicals may be safe to breathe, corrosive substances can become liberated when passed through a gas flame. Even at low concentrations, these chemicals can significantly contaminate the air supply and shorten the life of any gas burning appliance. The following is a list of some of the products which should be avoided:

- bleaches and chlorinated cleaning products
- paints and sprays
- water softeners (calcium or sodium chloride)
- leaking refrigeration equipment
- Freon from common aerosol dispensers

These chemicals are especially commons near swimming pools, beauty shops, dry cleaning establishments, laundry areas, workshops, and garages. **The warranty is void when failure is due to corrosion.**

## 2.7 VENTING

The responsibility of providing a suitable vent of adequate draft capacity and in good usable condition is that of the gas fitter/installer. Interference with the air supply for the boiler shall be prohibited.

Vent installation and type of gas vent or vent connector MUST follow all applicable national, provincial/state, and local codes, laws, regulations, and ordinances as described in *Section 2.2*.

For boilers for connection to gas vents or chimneys, vent installations shall be in accordance with Part 7, Venting of Equipment, of the National Fuel Gas Code, ANSI Z223.1 or Section 7, Venting Systems and Air Supply for Appliances, of the CAN/CGA B149, Installation Codes, or applicable provisions of the local building codes.

The venting shall be supported as required by applicable code(s). Horizontal runs shall slope upward not less than ¼ inch per foot (21 mm/m) from the boiler to the vent terminal. Vent cannot go horizontally to vent terminal without a chimney.

This unit must be installed with the factory supplied draft hood in place. The draft hood is a safety device designed to control chimney drafts that might affect combustion or blow out the pilot. The draft hood supplied with the boiler must not be altered. The minimum skirt height as indicated on the draft hood must be maintained.

Vent connectors serving the boiler must not be connected into any portion of mechanical draft systems operating under positive pressure.

### **Vent Terminal Information**

The minimum distance from the termination of a vent terminal to adjacent public walkways, adjacent buildings, operable windows and building openings shall be not less than those values specified in the *National Fuel Gas Code, ANSI Z223.1* and/or *CAN/CGA Installation Codes*.

For proper operation, the vent terminal must be kept free of snow and other debris at all times.

To prevent discoloration and degradation of building materials by flue gases and flue gas condensation, ensure that the vent terminal is installed clear of nearby obstacles. In all cases, installation shall be in accordance with code.

Maintain a minimum clearance of 4 feet (1.22 m) horizontally, and in no case above or below, unless a 4 foot (1.22 m) clearance is maintained from electric meters, gas meters, regulators and relief equipment.



## Removal of an Existing Boiler

When an existing boiler is removed from a common venting system, the common venting system is likely to be too large for proper venting of the appliances connected to it.

At the time of removal of an existing boiler, the following steps shall be followed with each appliance remaining connected to the common venting system placed in operation, while the other appliances remaining connected to the common venting system are not in operation.

- a) Seal any unused openings in the common venting system.
- b) Visually inspect the venting system for proper size and horizontal pitch and determine there is no blockage or restriction, leakage, corrosion and other deficiencies which could cause an unsafe condition.
- c) Insofar as is practical, close all building doors and windows and all doors between the space in which the appliances remaining connected to the common venting system are located and other spaces of the building. Turn on clothes dryers and any appliance not connected to the common venting system. Turn on any exhaust fans, such as range hoods and bathroom exhausts, so they will operate at maximum speed. Do not operate a summer exhaust fan. Close fireplace dampers.
- d) Place in operation the boiler being inspected. Follow the lighting instructions. Adjust the thermostat so the boiler will operate continuously.
- e) Test for spillage at the draft hood relief opening after 5 minutes of main burner operation. Use the flame of a match or candle, or smoke from a cigarette, cigar or pipe.
- f) After it has been determined that each appliance remaining connected to the common venting system properly vents when tested as outlined above, return doors, windows, exhaust fans, fireplace dampers and any other gas burning appliance to their previous conditions of use.
- g) Any improper operation of the common venting system should be corrected so the installation conforms to the *National Fuel Gas Code, ANSI Z223.1* and/or *CAN/CGA Installation Codes*. When re-sizing any portion of the common venting system, the common venting system should be resized to approach the minimum size as determined using the appropriate tables in Part 11 of the *National Fuel Gas Code, ANSI Z223.1* and/or *CAN/CGA Installation Codes*.

## **2.8 AUTOMATIC VENT DAMPER (SG-135 to SG-270)**

All boilers with an input of 300,000 Btu/h and under are supplied with an automatic vent damper. The following instructions must be observed:

- The automatic vent damper should be installed at the top of the factory supplied draft hood (Figure 1 - Alternate 3). No modifications to the automatic vent damper are permitted.
- The venting system must be arranged so that only the boiler is served by the automatic vent damper with which it was supplied.
- Connect the wiring harness from the boiler to the automatic vent damper as indicated on the supplied wiring drawings.
- The automatic vent damper position indicator should be clearly visible after installation.
- A minimum clearance of not less than 6 inches (153 mm) must be maintained between the automatic vent damper device and combustible construction. Provision must be made for service access to the automatic vent damper.
- The automatic vent damper must be in the open position when the boiler's main burner is operating.
- For orientation other than vertical, refer to automatic vent damper installation instructions.



## 2.9 BLOCKED VENT AND FLAME ROLL-OUT SAFETY SWITCHES (SG-135 to SG-270)

All boilers with an input of 300,000 Btu/h and under are equipped with blocked vent and flame roll out safety switches. The blocked vent safety switch is installed in the clip provided on the draft hood (Figure 6 - Alternate 1) or is mounted with screws (Figure 6 - Alternate 2). The blocked vent safety switch is pre-wired at the factory either directly to the boiler controls (Figure 6 - Alternate 1 & 2), or through a wiring harness for a boiler with an automatic vent damper (Figure 6- Alternate 3). If the vent becomes blocked a boiler shut down will occur. Ensure that the vent is free of obstructions.

The flame roll out safety switch will cause a boiler shutdown if the heat exchanger becomes blocked with soot or corrosion.

**WARNING**

**Shut down of the boiler by either the “Blocked Vent” or the “Flame Roll-out” safety switch is an indication that carbon monoxide may be improperly venting into the premises and the boiler must be serviced by a qualified person who is capable of determining the cause of the shut down and can take corrective action. Carbon monoxide is a lethal, colorless and odorless gas.**

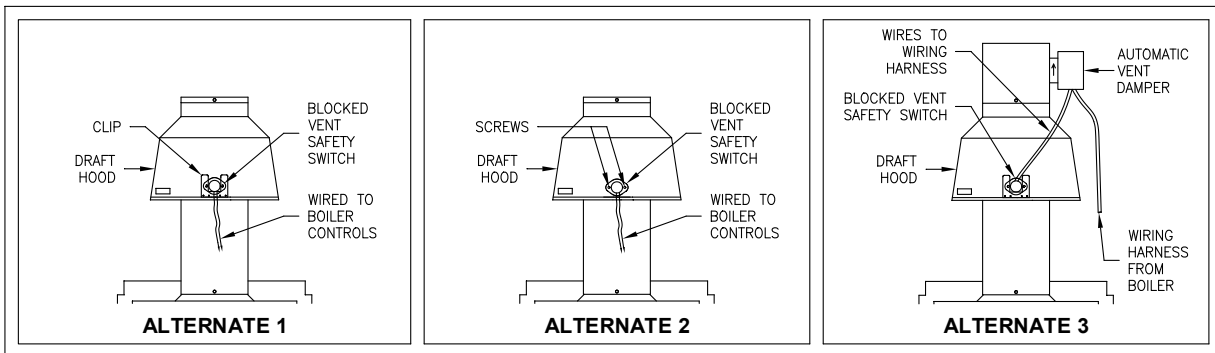

**FIGURE 6 - MOUNTING LOCATION OF BLOCKED VENT SAFETY SWITCH AND WIRE ROUTING**

## 2.10 BOILER PIPING SYSTEM

The boiler piping system of a hot water boiler connected to heating coils located in air handling units where they may be exposed to refrigerated air circulation must be equipped with flow control valves or other automatic means to prevent gravity circulation of the boiler water during the cooling cycle.

The boiler, when used in connection with a refrigeration system, must be installed so the chilled medium is piped in parallel with the boiler with appropriate valves to prevent the chilled medium from entering the boiler.

## 2.11 CORROSION PREVENTION (INTERNAL)

The use of oxygen barrier tubing is recommended to protect the system and its components (e.g. pump) from corrosion. Should your system include "non-oxygen barrier" tubing, please contact the factory or a heating professional for recommendations.

If freeze protection is required, use an inhibited propylene glycol solution which is specifically designed for hydronic heating systems and always maintained at a neutral pH (e.g. Fernox Alpha-11 or equivalent). Follow the supplier's instructions for proper use and maintenance. Do not use automotive antifreeze.

Some types of chemical additives can cause problems (e.g. accelerated corrosion, reduced efficiency, etc.) and could result in premature failure of the boiler heat exchanger and/or system components, especially when not properly used or maintained. Corrosion is a preventable condition and is not covered by the product warranty.



## 2.12 SYSTEM OPERATING REQUIREMENTS

### WARNING

**If you do not follow these instructions exactly, a fire or explosion may result causing property damage, personal injury or loss of life.**

Avoid unnecessary replenishment of system water. It can allow oxygen to enter the system and cause serious corrosion problems. As well, minerals dissolved in the water supply will precipitate when heated; minerals preferentially deposit in the heat exchanger. Do not draw water from the heating system for cleaning, flushing, etc.

*Super Hot* SG series boilers are designed for use in closed loop systems and are not intended for open systems, as in heating pool water or systems where water is constantly replenished. Operating the boiler in an open system will result in premature failure of the heat exchanger. *Super Hot* boilers may be used to heat water in open systems indirectly by installing a heat exchanger, such as the *Super Hot C-Coil*, to separate open and closed systems.

Heating systems with low temperature return water may cause flue gas moisture to condense on the boiler heat transfer surfaces, causing corrosion and restricting flue gas flow. Also, low temperature return water may overcool the flue gases, resulting in reduced vent suction. These are natural phenomena and are independent of the boiler design. As a guide to avoiding such corrosion and draft problems, it is imperative that the return water be not less than 135°F (57°C).

**SG SERIES BOILERS MUST ALWAYS BE USED WITH FORCED SYSTEM CIRCULATION.**

## 2.13 WATER QUALITY

Always use good quality water to prolong the life of the boiler. Water that is safe to drink and even city water is not necessarily good quality water for the boiler. The use of water treatment and filters can prevent corrosion and reduce sediment in the boiler. Water hardness, pH, and chlorides must be controlled to normal levels.

- **PH levels must be between 6.0 and 8.0**
- **Chlorine, chloride and sulfate concentrations must be below 100 parts per million.**

If you are unsure, use a water softening system or consult a qualified water treatment expert.

NOTE: All improper use as detailed above could void the warranty of the boiler.

## 2.14 PRESSURE RELIEF VALVE

### WARNING

**The pressure relief valve discharges pressurized hot water and/or steam. Steam exiting the discharge outlet can explosively expand in any direction. Always maintain a safe distance from the discharge pipe outlet in order to avoid potential contact with exiting hot water or steam.**

A pressure relief valve is supplied as standard equipment. The pressure relief valve is extra protection against damage that could be caused by malfunctioning controls or excessive water pressure. If a pressure relief valve is not used, the warranty is void.

The pressure relief valve should be installed on the boiler outlet with its spindle vertical. The connection between the boiler and the relief valve must have at least the area of the valve inlet.

A discharge pipe should be used. The discharge pipe outlet should be positioned over a suitable drain and so arranged that there will be no danger of being scalded. The discharge pipe must pitch down from the valve and should be no smaller than the outlet of the valve. The end of the discharge pipe should not be concealed or threaded and should be protected from freezing. Extensive runs, traps or bends could reduce the capacity of the pressure relief valve.



No valve of any type should be installed between the pressure relief valve and unit or in the discharge pipe. The pressure relief valve is a code requirement. Field installation of the relief valve must be consistent with the ANSI/ASME Boiler and Pressure Vessel Code, Section IV.

## 2.15 ELECTRICAL WIRING

### **DANGER – RISK OF ELECTRIC SHOCK**

**This boiler may be connected to more than one electrical circuit. Disconnect all electrical power before installation or service. All circuit breakers ahead of and at the boiler must be off. Failure to do so may result in severe personal injury or death.**

All electrical wiring must conform to the requirements in *Section 2.2*.

Run a separate circuit from the electrical service panel through a fused disconnect switch to the boiler. This boiler must be electrically bonded to ground in accordance with the requirements of the authority having jurisdiction or, in the absence of such requirements, with the *National Electrical Code, ANSI/NFPA 70* (current edition) and and/or the *Canadian Electrical Code, CSA C22.1 Part 1* (current edition). Field wiring shall conform to *Section 2.2* and to the temperature limitations of Type T [63°F (35°C) rise] or better.

Make connections as shown in the wiring diagram provided with this manual. Also, a wiring diagram sticker is provided on the inside of the door panel of the boiler.

## **Startup Instructions**

## **Section 3**

### 3.1 PRE-STARTUP

- a. Fill entire heating system with water and vent or purge air from system. Add water as needed to reach boiler operating pressure. Water should be of suitable quality. Do not use water with high hardness.
- b. Check for and repair any leaks in water piping.
- c. Check burners to see that they are not dislodged.
- d. Check for proper installation of pressure relief valve, draft hood, and venting.
- e. Check that the electrical wiring matches the wiring diagram in this manual or on the boiler.
- f. Check if the flame roll out safety switch and blocked vent safety switch are properly located and wired. (Applicable on models SG-135 to SG-270)
- g. Use a soap solution to check for leaks in gas piping from meter to boiler pilot and manifold. Repair and retest any leaks found.
- h. Operate circulating pump and vent all radiation units and high points in system piping.

### 3.2 STARTUP

#### **WARNING**

**The following instructions are intended as a guide for qualified persons. Before lighting the boiler, the pre-startup instructions of *Section 3.1* MUST be performed. If you do not follow these instructions exactly, a fire or explosion may result causing property damage, personal injury or loss of life.**





**WARNING**

**Should boiler overheat, or the gas supply fail to shut off, do not turn off or disconnect the electrical supply to the circulating pump. Instead, shut off the gas supply at a location external to the boiler.**

**a. Intermittent pilot with combination gas valve**

This boiler does not have a continuous pilot flame. It is equipped with an ignition device which automatically lights the pilot. Do not try to light the pilot by hand.

In the event of failure of any component, either the system will not operate or it will go into safety lockout.

- 1) Make sure the Gas Valve and all electrical power to the boiler is "OFF".
- 2) Set room thermostat to the lowest setting.
- 3) Connect a manometer at pressure tapping on downstream section of gas valve.
- 4) Wait five minutes to clear out any gas. If you smell gas, STOP! Follow the safety instructions provided in *Section 1.1* under WHAT TO DO IF YOU SMELL GAS. Remember that propane does not vent upward naturally.
- 5) Set the controller as described in *Section 1.6* and check operation as follows:
  - a) Set thermostat above room temperature to call for heat and turn power on for the boiler.
  - b) Watch for spark at pilot burner. All models will automatically lockout if no pilot flame is detected within 15 seconds. Automatic retry will occur in 5 minutes.
- 6) Turn Gas Valve to ON. Pilot burner should ignite, followed by main burners. Check main and pilot burners and adjust pilot, if necessary, as described in *Section 3.3*.
- 7) Assure that all other gas appliances are turned off, including their pilot flames.
- 8) Check manifold pressure reading on the manometer and make necessary adjustments. Check that burner input matches rating plate input.
- 9) Return thermostat and controls to normal operation settings.

**b. Intermittent pilot with non-combination gas valve**

This boiler does not have a continuous pilot flame. It is equipped with an ignition device which automatically lights the pilot. Do not try to light the pilot by hand.

In the event of failure of any component, either the system will not operate or it will go into safety lockout.

- 1) Make sure the Main and Pilot Gas Valve and all electrical power to the boiler are "OFF".
- 2) Set room thermostat to the lowest setting.
- 4) Connect a manometer at pressure tapping on downstream section of gas valve.
- 4) Wait five minutes to clear out any gas. If you smell gas, STOP! Follow the safety instructions provided in *Section 1.1* under WHAT TO DO IF YOU SMELL GAS. Remember that propane does not vent upward naturally.
- 5) Check the ignition control module as follows:
  - a) Set thermostat above room temperature to call for heat and turn power on for the boiler.
  - b) Watch for spark at pilot burner on units equipped with spark ignition. All models will automatically lockout if no pilot flame is detected within 15 seconds. Automatic retry will occur in 5 minutes.
- 6) Turn Pilot and Main Gas Valve to ON. Pilot burner should ignite, followed by main burners. Check main and pilot burners and adjust pilot, if necessary, as described in *Section 3.3*.
- 7) Assure that all other gas appliances are turned off, including their pilot flames.
- 8) Check manifold pressure reading on the manometer and make necessary adjustments. Check burner input to match rating plate input.
- 9) Return thermostat and controls to normal operation settings.



### 3.3 CHECK BURNER SYSTEM

To maintain safe and efficient operation, examine the burner system regularly through the inspection hole near the pilot tube.

#### Check condition of burner system

It is possible for parts of the burner system to become plugged, cracked, eroded and/or dislodged resulting in unsafe operation.

#### Pilot Flame

Remove cap screw cover on gas or pilot valve, and then adjust gas flow to the point where sensor rod is completely enveloped by the flame (Figure 7), but not necessarily glowing red. Replace and tighten cap.

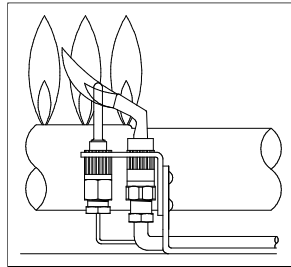

FIGURE 7 - PILOT FLAME ADJUSTMENT

#### Check for lifting

Flames should not lift excessively from the burner ports. The flames may lift slightly during ignition or when the burners are cold.

#### Check ignition and extinction

Ignition should flow quickly and smoothly across all the burners. Popping noises or explosions from the burners during ignition, extinction or normal burner operation indicates the need for service.

#### Check flame color

An extremely yellow flame, as seen on a burning candle or match, is an indication of incomplete combustion and is usually accompanied by the formation of soot and carbon monoxide (carbon monoxide is a lethal, colorless and odorless gas). If soot is allowed to accumulate, it will partially restrict free passage of products of combustion to the flue. Under typical operating conditions, the flame should have a distinct bright blue inner cone and a blue/orange outer cone.

**If any of the above problems are observed or the burner system does not operate properly, immediately take corrective measures.**

### 3.4 AQUASTAT ADJUSTMENT

An optional aquastat may be installed to control the main burner firing by sensing outlet water temperature. The optional aquastat should be set a minimum of 20°F (10°C) above the setting of the high limit of the integrated boiler controller.

### 3.5 GAS MANIFOLD PRESSURE

The designated manifold pressures are as shown in the table below. A 1/8" NPT tapping is provided on the manifold or gas valve for connecting a manometer to check this pressure. Both natural gas and propane models are furnished with gas valves which have a built in gas pressure regulator. If necessary, adjust to the proper value by removing cap and turning adjusting screw clockwise to increase manifold pressure or counterclockwise to decrease manifold pressure.

Model	Natural Gas	Propane
SG	3.5" W.C.	10.0" W.C.



**3.6 CHECK INPUT & ORIFICES**

For safety, the input shown on rating plate must not be exceeded. Check with the table below that the orifice size and input rate shown on the rating plate match your application, i.e. boiler model, fuel type, and altitude. See *SG Dimensions and Specifications* section to find your boiler model's input rate.

FOR CANADA				
Model	Natural Gas		Propane	
	0 to 2,000 feet	2,000 to 4,500 feet	0 to 2,000 feet	2,000 to 4,500 feet
SG	#43 orifice standard input	#44 orifice 10% de-rate input	#54 orifice standard input	#55 orifice 10% de-rate input
NOTE: For elevations above 4,500 feet reduce high altitude input 4% for each additional 1000 feet. Reference <i>Natural Gas and Propane Installation Code B149.1</i> , 3.22 High Altitude Installations				
<u>Example of High Altitude De-rate</u>				
Boiler: SG-270				
Altitude: 5,500 feet				
Standard Input (0 to 2,000 ft) = 270,000 Btu/h (from page 3)				
High Altitude Input (2,000 to 4,500 ft) = De-rate Standard Input by 10% (see above table)				
= 270,000 Btu/h x (1 - 0.10)				
= 270,000 Btu/h x 0.90				
= 243,000 Btu/h				
% Reduction for additional 1000 ft = 4% x 1 = 4%				
Input at 5,500 ft = De-rate High Altitude Input by 4%				
= 243,000 Btu/h x (1 - 0.04)				
= 243,000 Btu/h x 0.96				
= <u>233,280 Btu/h</u>				

FOR UNITED STATES OF AMERICA				
Model	Natural Gas		Propane	
	0 to 2,000 feet	Over 2,000 feet	0 to 2,000 feet	Over 2,000 feet
SG	#43 orifice standard input	Input must be reduced 4% for each 1000 feet above sea level. *	#54 orifice standard input	Input must be reduced 4% for each 1000 feet above sea level. *
*Reference <i>National Fuel Gas Code ANSI Z223.1</i> , 8.1.2 High Altitude.				

Small adjustments to the input rate can be made by varying the manifold pressure. Normally it should be adjusted no more than 0.2 inch w.c. for natural gas or 0.5 inch w.c. for propane from the manifold pressure specified on the rating plate.

<b>DANGER</b>
<b>Exceeding the allowable input rate can produce dangerous concentrations of carbon monoxide, and cause the boiler to overheat resulting in severe personal injury, death or substantial property damage. Carbon monoxide is a lethal, colorless and odorless gas.</b>



## Input Rate Test

Consult gas company to determine the heating value of the gas supplied in Btu per cubic feet. Operate boiler for 15 minutes starting with all parts at room temperature and check input by clocking gas meter with all other gas appliances turned off, including their pilot flames. Use the following formula:

$$\text{INPUT (Btu/h)} = \frac{(3600) \times (\text{High Heating Value of Gas in Btu/cu.ft.}) \times (\text{Volume of Cubic Feet Timed})}{\text{Clocked Time in Seconds}}$$

To ensure accuracy for rating, clock enough cubic feet of gas so that there is at least one revolution of the test dial and the clocked time is at least 60 seconds.

## Two Stage or Full Modulating Gas Valve

When a two-stage or modulating gas valve is used, it must be checked for correct input at both "High" and "Low" fire settings. The clocked input rate **MUST** be within the "Minimum Input" and the "Input" as specified on the boiler's rating plate. To force a two-stage or full modulating gas valve to low fire, see the valve manufacturer's instructions. Perform the Input Rate Test described above and adjust manifold pressure of High and Low settings as necessary. For altitudes above 2000 feet, **DO NOT** de-rate the "Minimum Input" rate.

### **3.7 CHECK FOR DRAFT HOOD SPILLAGE**

#### **WARNING**

**Continuous spillage at the draft hood relief opening may result in severe personal injury, death or substantial property damage.**

After the main burners have operated for 5 minutes, check to see that combustion products are going up the chimney or gas vent properly by passing a lighted match (or smoke from a cigar, cigarette, or pipe) around the edge of the relief opening of the draft hood. If the chimney or gas vent is drawing properly, the match flame or smoke will be drawn into the draft hood. If not, the combustion products will tend to extinguish this flame. While performing this test, make sure all exhaust fans, air movers, and gas appliances are operating and doors and windows are closed. If the combustion products are escaping from the relief opening of the draft hood, **IMMEDIATELY** shutdown the boiler and make proper adjustments or repairs.

### **3.8 CHECK OF CONTROLS**

While the boiler is in operation, lower the high limit setpoint ( $HL_{-}$ ) on boiler controller or aquastat setting (as applicable) below the current outlet water temperature. The burners should shut off. Set the high limit setpoint ( $HL_{-}$ ) or aquastat setting higher than the current outlet water temperature and the burners should re-ignite. Return the hi-limit setpoint ( $HL_{-}$ ) or aquastat to its original setting and make sure boiler cycles normally. Repeat this type of check on the optional aquastat (when used), thermostat and other system controls to ensure all are working satisfactorily. If any of the safety or controls do not function, necessary corrections should be made immediately.

### **3.9 CHECK FOR GAS LEAKS**

To identify gas leaks, smell for gas around boiler area and gas piping connections (See *Section 1.1*). To check a specific area for leakage, spray a mixture of soap and water onto the suspected area – active bubbling indicates a gas leak. **DO NOT TEST FOR LEAKS WITH AN OPEN FLAME.** Gas leaks must be repaired immediately.



**3.10 INSTALLER'S CHECKLIST**

	<i>Reference Section</i>
<input type="checkbox"/> The information printed on the boiler rating plate matches the application (i.e. input, altitude and fuel type).	3.6
<input type="checkbox"/> All applicable electrical codes have been met.	2.2, 2.14
<input type="checkbox"/> Gas piping has been purged and checked for leaks with a soap solution.	2.2, 2.4, 3.9
<input type="checkbox"/> System is filled with water and all air has been purged. Only oxygen barrier tubing has been used.	2.11, 2.12
<input type="checkbox"/> A manometer has been used to check the manifold pressure and gas supply pressure against requirements printed on boiler rating plate.	3.2, 3.5
<input type="checkbox"/> Bypass or mixing valve has been used to prevent return water less than 135°F.	2.12
<input type="checkbox"/> All applicable venting codes have been met. Air openings sized to provide adequate supply air for combustion, flue gas dilution and ventilation and will not be blocked off.	2.2, 2.5, 2.6, 2.7
<input type="checkbox"/> Check for spillage at draft hood and other areas susceptible to spillage.	3.7
<input type="checkbox"/> Operate the boiler for 15 minutes, then clock and calculate Btu/h input rate. The input rate must not exceed that specified on the boiler rating plate. Clocked BTU/H Input Rate: _____	3.6
<input type="checkbox"/> Perform check of temperature controls: aquastat, optional aquastat (when used), and thermostat.	3.4, 3.8
<input type="checkbox"/> Test any other controls as specified by the manufacturer.	
<input type="checkbox"/> Visually inspect main burners and pilot to ensure proper flame operating characteristics and ignition/extinction is ok.	3.3
<input type="checkbox"/> Allow the boiler to cycle a few times to ensure functions are operating correctly.	
<input type="checkbox"/> Close main and pilot shut-off valve and check that burners and pilot flame extinguish.	
<input type="checkbox"/> Clearly identify emergency shut-off devices and make the user or owner aware of their location and method of operation.	
<input type="checkbox"/> Fill in the contact information on the cover of the User's Information Manual and leave both manuals in the envelope adjacent to the boiler.	

**NOTE: INSTALLER'S RESPONSIBILITY**

*"Before leaving installations, installers shall ensure that an appliance, accessory, component, equipment, or piping and tubing installed by them comply with the Code requirements, and the person initially activating the appliance shall ensure that the appliance is in safe working order."*

*CSA B149.1-05 Natural Gas and Propane Installation Code*

**Service & Maintenance Instructions****Section 4****4.1 SERVICE & MAINTENANCE INSTRUCTIONS****WARNING**

Label all wires prior to disconnection when servicing controls. Wiring errors can cause improper and dangerous operation.

**WARNING**

If any part of this boiler has been under water, inspect the boiler and replace any part of the control system and any gas control which has been under water.

This boiler has been designed to provide years of trouble-free performance in normal installations. The owner or user should conduct a general external examination covering all items on the "User Checklist" at the beginning of each heating season and in mid-heating. In addition, the owner or user will have the boiler inspected by qualified service technician or gas supplier's service person at least **once every year** at the beginning of the heating season for continued safe operation. Note that some operating conditions may require more frequent inspections.

The qualified service technician or gas supplier's service person should follow the "Service Checklist". The "Service Checklist" must only be used by a qualified service technician or gas supplier's service person.

**Verify proper operation after servicing.**

**4.2 CLEANING PROCEDURE**

1. Shutdown the boiler as described in the lighting instructions in *Section 1.6*.
2. Inspect flue gas passages and burners for the presence of soot, rust or scale.
3. If necessary, use a wire brush and vacuum to clean and remove any blockages. Plugged burner ports must be cleared.
4. Replace any parts which have severely corroded.
5. Reassemble parts removed during cleaning as they were before, ensuring air tightness of flue gas passages.
6. Corrosion can be caused by low return water temperature or a contaminated air supply. Sooting can be caused by improper burner adjustment. Check and adjust as necessary.
7. Return boiler to operation following lighting instructions in *Section 1*.



4.3 SERVICE CHECKLIST

	<i>Reference Section</i>
<input type="checkbox"/> Do not store anything against the boiler or allow dirt or debris to accumulate in the area immediately surrounding the boiler. The flow of supply and exhaust air must not be obstructed.	2.5
<input type="checkbox"/> Check air openings are not restricted and complies with applicable code(s). Adequate supply air is necessary for combustion, flue gas dilution and ventilation.	2.2, 2.5, 2.6, 2.7
<input type="checkbox"/> When the boiler has operated for several minutes, check for spillage at draft hood, venting ducts, and other areas susceptible to spillage.	3.7
<input type="checkbox"/> Check externally the draft hood and vent system for soot, rust scale or corrosion. Check for dislodged venting or possible leaks in venting ducts.	
<input type="checkbox"/> Remove the draft hood from the boiler and inspect the flueways for the presence of soot or rust scale. Inspect the draft hood and smoke pipe connecting the draft hood to the flue for rust or corrosion before replacing the draft hood. The presence of soot, rust scale or corrosion indicates misadjustment.	4.2
<input type="checkbox"/> Inspect and, if necessary, clean the pilot burner and main burner. Check burners to see that they are not cracked or dislodged.	3.3, 4.2
<input type="checkbox"/> Visually check the pilot and main burner flames. A yellow flame caused by improper adjustment is always accompanied by formation of soot which, if allowed to continue, will partially restrict free passage of products of combustion to the flue.	3.3
<input type="checkbox"/> Check that gas piping is secured. Smell for gas leaks around boiler and gas piping connections. Gas leaks can also be checked for using a soap solution; do not use an open flame to check for leaks. Note: Propane is heavier than air and pools in a low area in the event of a leak.	3.9
<input type="checkbox"/> Inspect boiler for signs of leaks or corrosion. Inspect for leaks in the water piping and at water piping connections.	
<input type="checkbox"/> Circulating pumps used with hot water heating systems should be inspected for water leaks.	
<input type="checkbox"/> Check for weeping at pressure relief valve outlet during normal operation.	2.13
<input type="checkbox"/> Listen for unusual audible sounds in the boiler. Any audible sounds in the boiler system may be indications of scaling or lack of sufficient water flow and the system should be checked without delay. Scaling is due to improper maintenance. It is not the fault of the boiler. Scale damage is not covered by warranty.	2.12, 4.4
<input type="checkbox"/> Check the temperature and pressure gauge and expansion tank pressure is within an acceptable range for the heating system.	
<input type="checkbox"/> Keep boiler area clear and free from combustible materials, gasoline and other flammable vapors and liquids. Combustible materials, gasoline and other flammable vapors and liquids should not be stored in the area of the boiler.	
<input type="checkbox"/> Checks should be made on ignition system, operation controls and safety shut-off valves for gas tightness.	2.4, 3.9
<input type="checkbox"/> If applicable, inspect low water cutoff for proper operation.	
<input type="checkbox"/> Check for proper operation of the blocked vent and flame roll-out safety switches.	
<input type="checkbox"/> The emergency shut-off devices are identified and the owner is aware of their location and method of operation.	



## 4.4 CAUTION: WATER REPLENISHMENT

Avoid unnecessary replenishment of system water. It can allow oxygen to enter the system and cause serious corrosion problems. As well, an excessive amount of minerals may be deposited in the heat exchanger. Do not draw water from the heating system for cleaning, flushing, etc.

Any audible sounds in the boiler system may be indications of scaling or lack of sufficient water flow and the system should be checked without delay. Scaling is due to improper maintenance. It is not the fault of the boiler. Scale damage is not covered by warranty.

## 4.5 REFRACTORY HANDLING PROCEDURE

### WARNING

**The mineral block and fiberglass wool used in this product are RCFs (Refractory Ceramic Fibers). RCFs pose a possible cancer hazard by inhalation and can cause respiratory, skin and eye irritation.**

**After mineral block has been fired, it will produce increased levels of nuisance dust and poses increased carcinogenic risk.**

Follow the precautionary measures below before attempting service or access.

### PRECAUTIONARY MEASURES:

- Avoid breathing fibers and contact with skin and eyes.
- Use a National Institute for Occupational Safety and Health (NIOSH) approved dust/mist respirator.
- Wear long-sleeved, loose fitting clothing, gloves and eye protection.
- Wash work clothes separately from other clothing. Rinse washer thoroughly.
- Operations such as sawing, blowing, tear out and spraying may generate airborne fiber concentration requiring additional protection.
- Use a vacuum with a HEPA filter for clean up.
- Dispose of all RCF scrap and dust in a closed airtight plastic bag.

### FIRST AID MEASURES:

- Eye contact – Flush eyes with water to remove dust for at least 15 minutes. If irritation persists, seek immediate medical attention.
- Skin contact – Wash affected area gently with soap and warm water after handling.
- Difficulty breathing – Move to an area of clean fresh air. Seek immediate medical attention if difficulties persist.
- Ingestion – Do not induce vomiting. Drink plenty of water. Seek immediate medical attention.





**Replacement Parts** **Section 5**

**NOTE:** To supply the correct part it is important that you state the boiler model number, serial number and type of gas when applicable.

Any part returned for replacement under standard company warranties must be properly tagged with Return Goods Authorization form (R.G.A.), completely filled in with the boiler serial number, model number, etc., and shipped to the Company freight prepaid.

If determined defective by the Company and within warranty, the part will be returned in kind or equal substitution, freight collect. Credit will not be issued.

Refer to Figures 8, 9 and 10 for replacement parts.

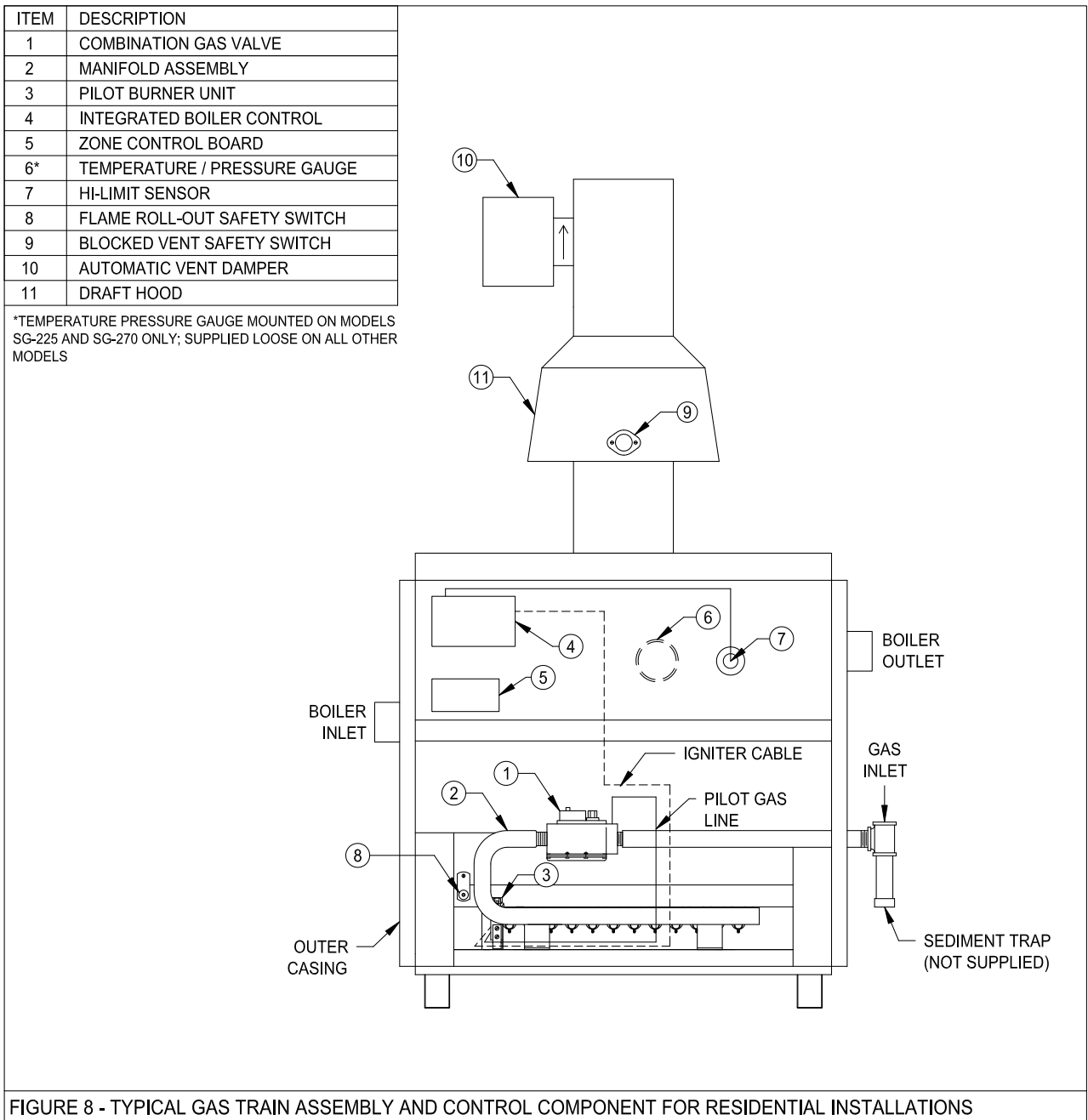



ITEM	DESCRIPTION	ITEM	DESCRIPTION
1	TRANSFORMER	9	REDUNDANT GAS VALVE
2	OPERATING / HIGH LIMIT AQUASTAT	10	MAIN GAS VALVE
3	TEMPERATURE / PRESSURE GAUGE	11	IGNITION CONTROL MODULE (ELECTRONIC IGNITION)
4	SAFETY HIGH LIMIT AQUASTAT	12	MANUAL MAIN SHUT-OFF VALVE (AB COCK)
5	PILOT REGULATOR/SOLENOID	13	90° ELBOW
6	P2S PILOT SHUT-OFF VALVE	14	MANIFOLD ASSEMBLY
7	1/4" TEE & PLUG	15	PILOT BURNER UNIT
8	MANUAL MAIN SHUT-OFF VALVE (AB COCK)	16	DRAFT HOOD
		17	GAS MANIFOLD PRESSURE TAP (1/8" NPT)

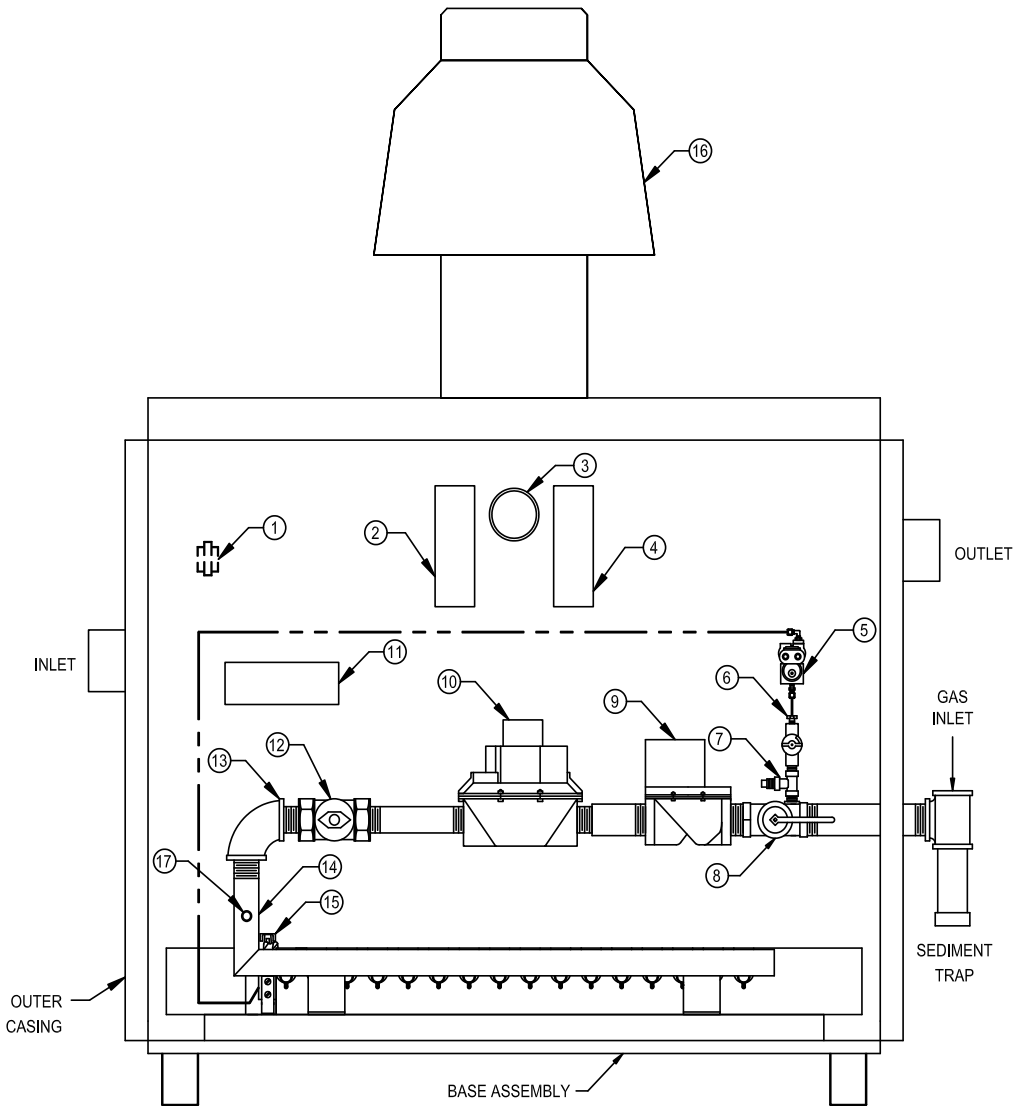

**NOTES:**

- 1. SOME MODELS MAY BE SUPPLIED WITH A COMBINATION GAS VALVE.
- 2. SOME MODELS MAY BE SUPPLIED WITH A DUAL OPERATING / SAFETY HIGH LIMIT AQUASTAT.
- 3. ITEMS SHOWN MAY NOT BE PRESENT ON ALL MODELS.

SG-U-034-03

FIGURE 9 - TYPICAL GAS TRAIN ASSEMBLY AND CONTROL COMPONENT LAYOUT FOR COMMERCIAL INSTALLATIONS



NO.	DESCRIPTION	NO.	DESCRIPTION	NO.	DESCRIPTION
1*	AUTOMATIC VENT DAMPER	12	INSPECTION DOOR	24	BURNER TRAY
2	DRAFT HOOD	13	ROLL-OUT SHIELD	25	REAR BURNER SUPPORT
3	TOP PANEL	14	FRONT REFRACTORY HOLDER	26	BOILER BASE
4	LEFT SIDE PANEL	15	FRONT REFRACTORY	27	RIGHT SIDE REFRACTORY
5	LEFT SIDE REFRACTORY HOLDER	16	FRONT SEAL	28	RADIATION SHIELD
6	FLUE COLLECTOR NOZZLE	17	HEAT EXCHANGER ASSEMBLY	29	BOILER LEG
7	LEFT SIDE REFRACTORY	18	REAR REFRACTORY	30	RIGHT SIDE REFRACTORY HOLDER
8	BAFFLE	19	REAR REFRACTORY HOLDER	31	RIGHT SIDE PANEL
9	FLUE COLLECTOR	20	REAR PANEL	32	PILOT BURNER ASSEMBLY (NOT SHOWN)
10A	DOOR PANEL (MODELS SG-315 THRU SG-495)	21	MANIFOLD	33	FIBERGLASS INSULATION C/W FOIL (NOT SHOWN)
10B	DOOR PANEL (MODELS SG-135 THRU SG-270)	22	BURNER	34	FIBREFRAX BLANKET INSULATION (NOT SHOWN)
11	CONTROL PANEL	23	FRONT BURNER SUPPORT		

\* ITEM 1 PROVIDED ON MODELS WITH INPUT RATE 300,000 BTU/H AND UNDER

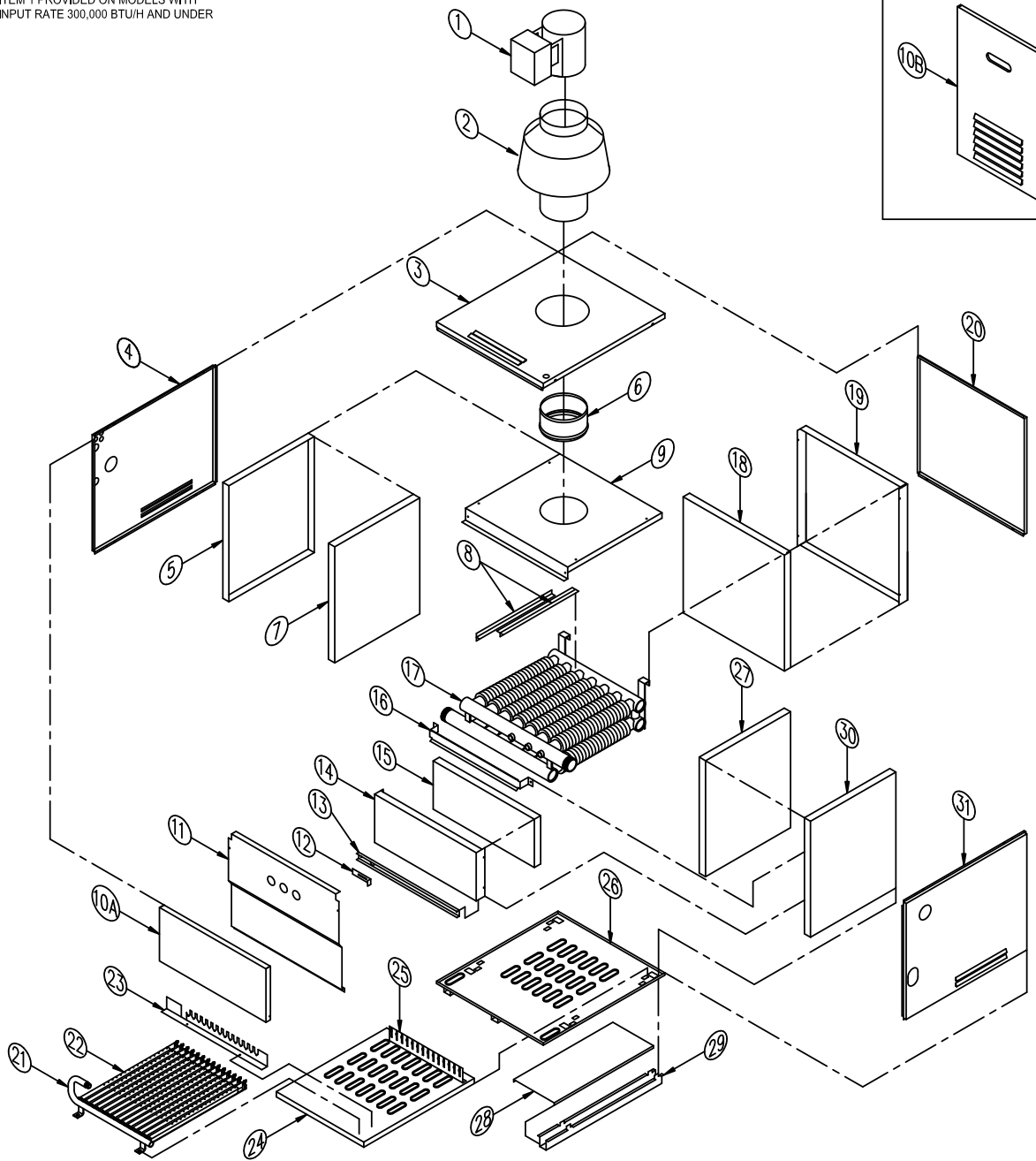

SG-U-019-03

FIGURE 10 - SG SERIES BOILER - GENERAL ASSEMBLY PARTS LIST

**Wiring Diagrams****Section 6****Simplified Wiring Instructions for models SG-135 to SG-270** **IMPORTANT**

- Disconnect power supply to boiler before wiring zone control board.
- All wiring must comply with applicable codes, ordinances and regulations.
- The non-replaceable fuse on the Zone Control Board will be blown if 240 Vac is connected to the board or if the 24 Vac system is even momentarily shorted out.

**A: Line Voltage Connections**

Connect 120 Vac, 60 Hz, single phase power to terminals L1 (HOT) and L2 (NEUTRAL). Strip wire ends to a maximum of 3/16" before inserting into terminal block. Tighten terminal screw clamps. Connect ground wire to ground screw "G" on the boiler control panel.

**B: Zones**

Remove zone one plug-in terminal block. Connect 24 Vac thermostat leads to terminals TH1 and TH2 on plug-in terminal block. Connect normally closed zone valve 24 Vac motor leads to terminals ZV1 and ZV2. Connect zone valve "end switch" leads to terminals ES1 and ES2. Strip wire ends to a maximum of 3/16" before inserting into terminal block. Tighten terminal screw clamps. Re-insert plug-in terminal block into mating connector on Zone Control Board. Repeat for zones 2, 3, and 4 as required.

**C: Optional Second Pump**

A second pump (120 Vac, 1/6 HP maximum) may be connected to terminals P2 (HOT) and P2C (NEUTRAL).

**D: Jumpers**

Jumpers J1 and J2 are factory set for a multi-zone installation.

**E: For Single Zone Applications**

Install jumper J2 and connect 24 Vac thermostat leads to terminals TH1 and TH2 on Zone 1 plug-in terminal block.

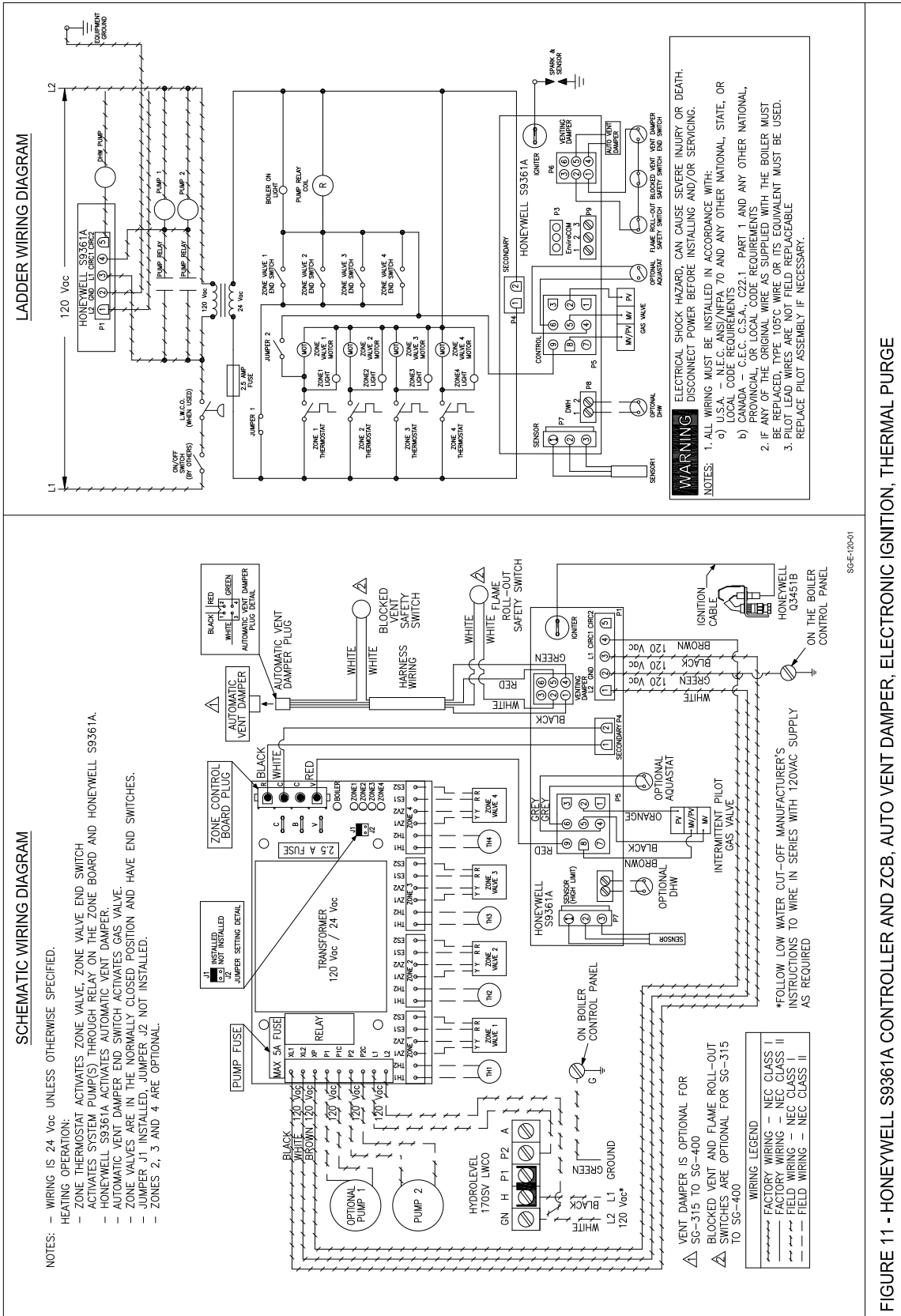

FIGURE 11 - HONEYWELL S9361A CONTROLLER AND ZCB, AUTO VENT DAMPER, ELECTRONIC IGNITION, THERMAL PURGE

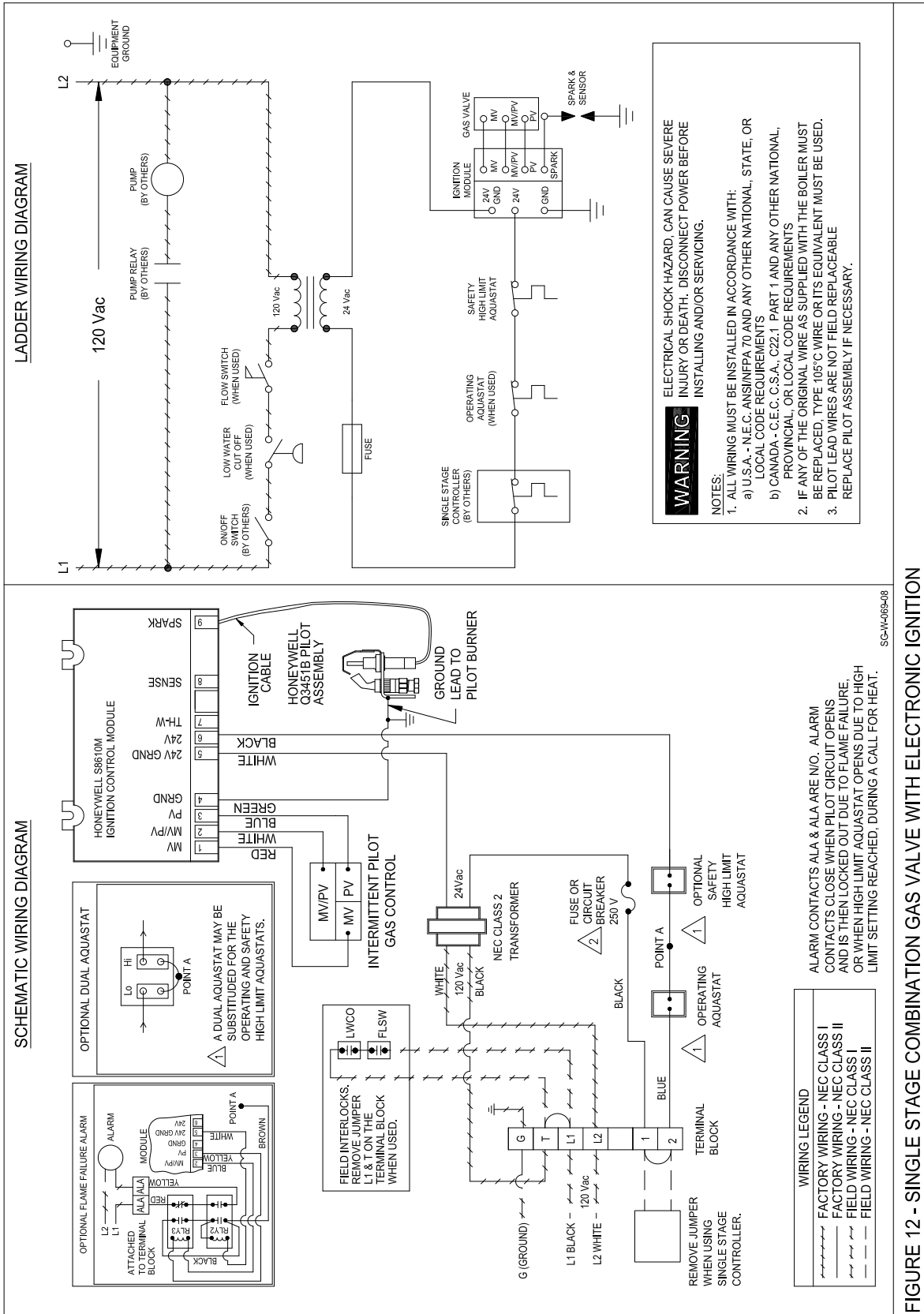
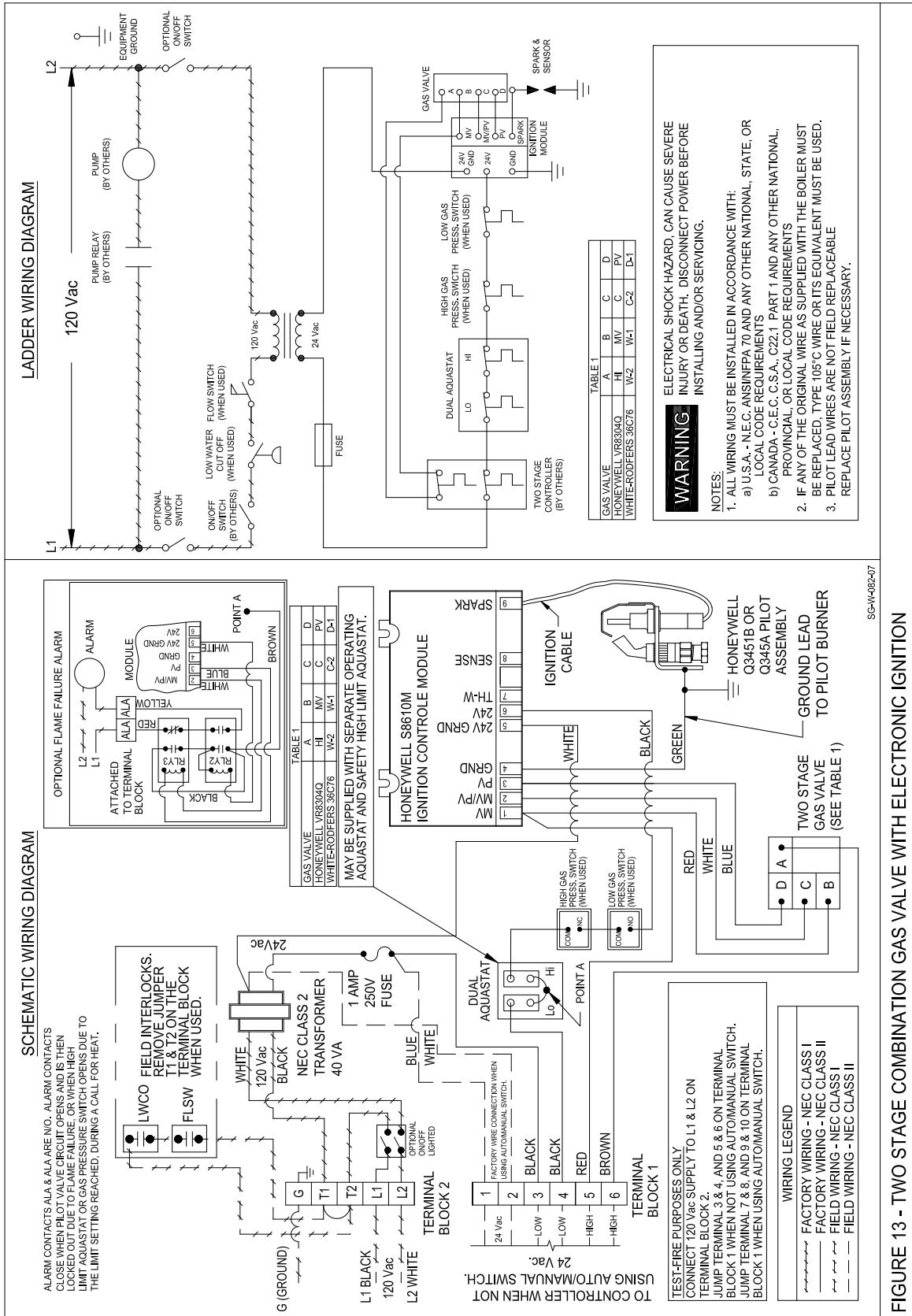

FIGURE 12 - SINGLE STAGE COMBINATION GAS VALVE WITH ELECTRONIC IGNITION

SG-W4069-08



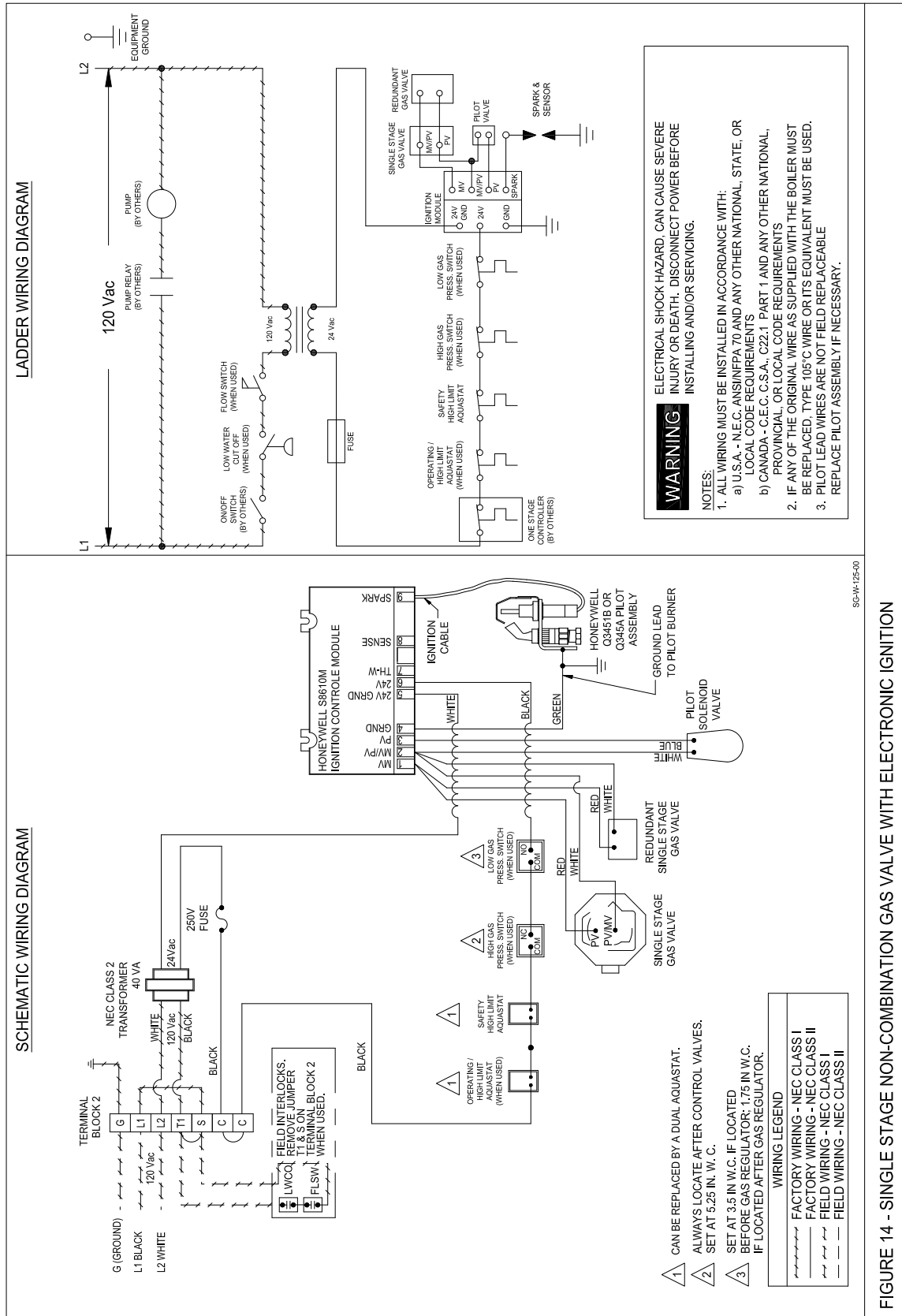
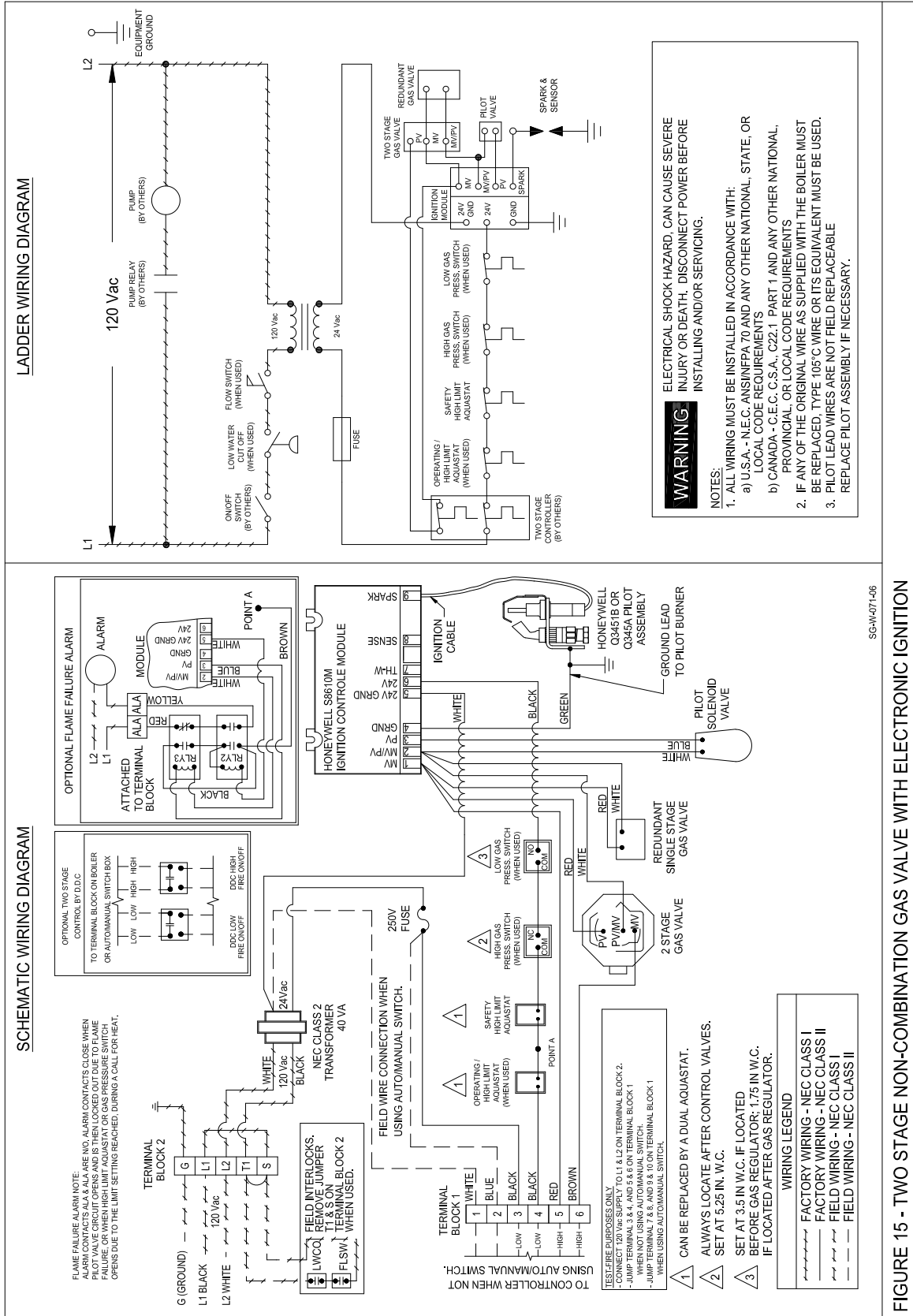

FIGURE 14 - SINGLE STAGE NON-COMBINATION GAS VALVE WITH ELECTRONIC IGNITION





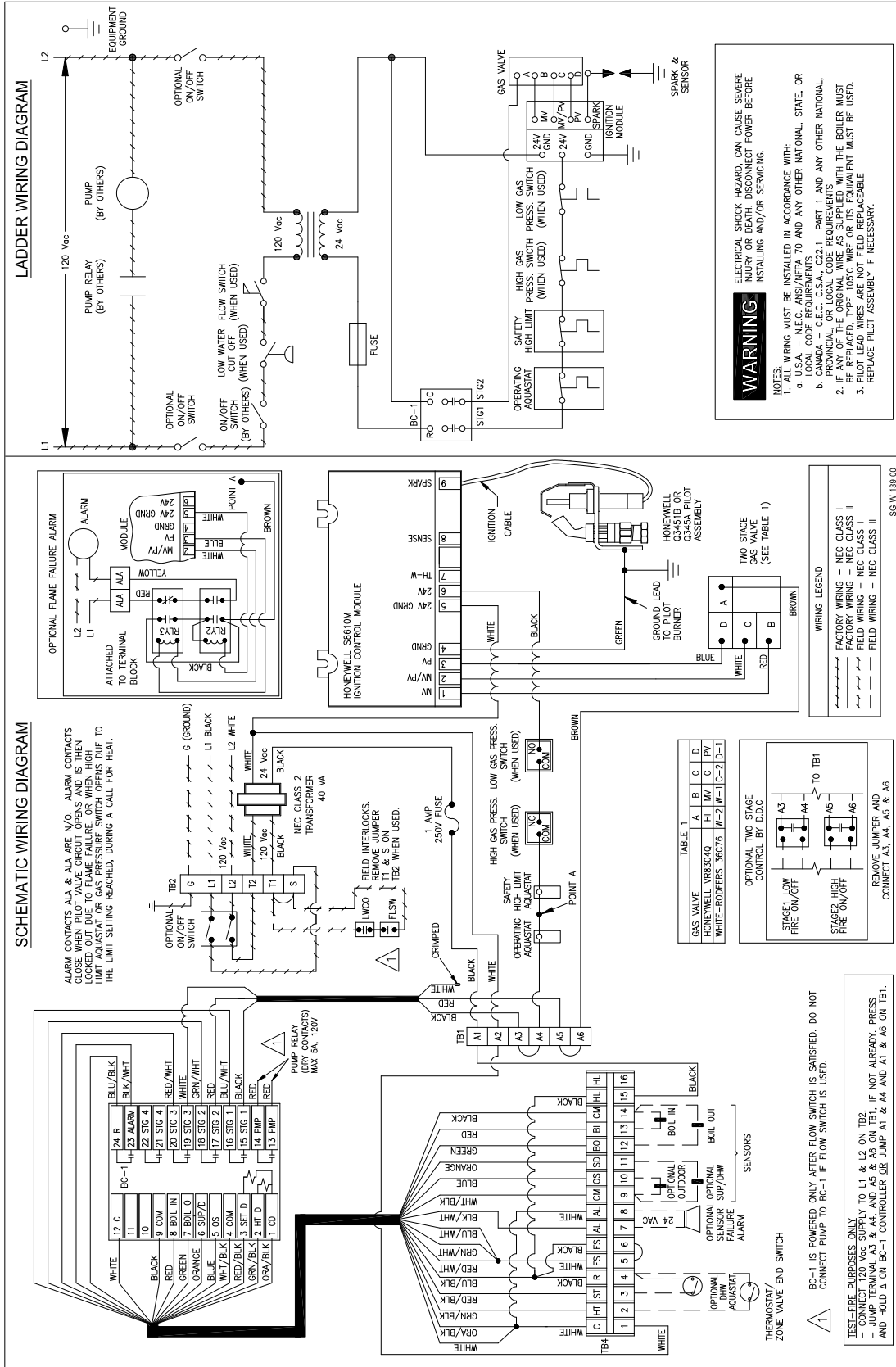

FIGURE 16 - TWO STAGE COMBINATION GAS VALVE WITH ELECTRONIC IGNITION, BC-1 CONTROLLER

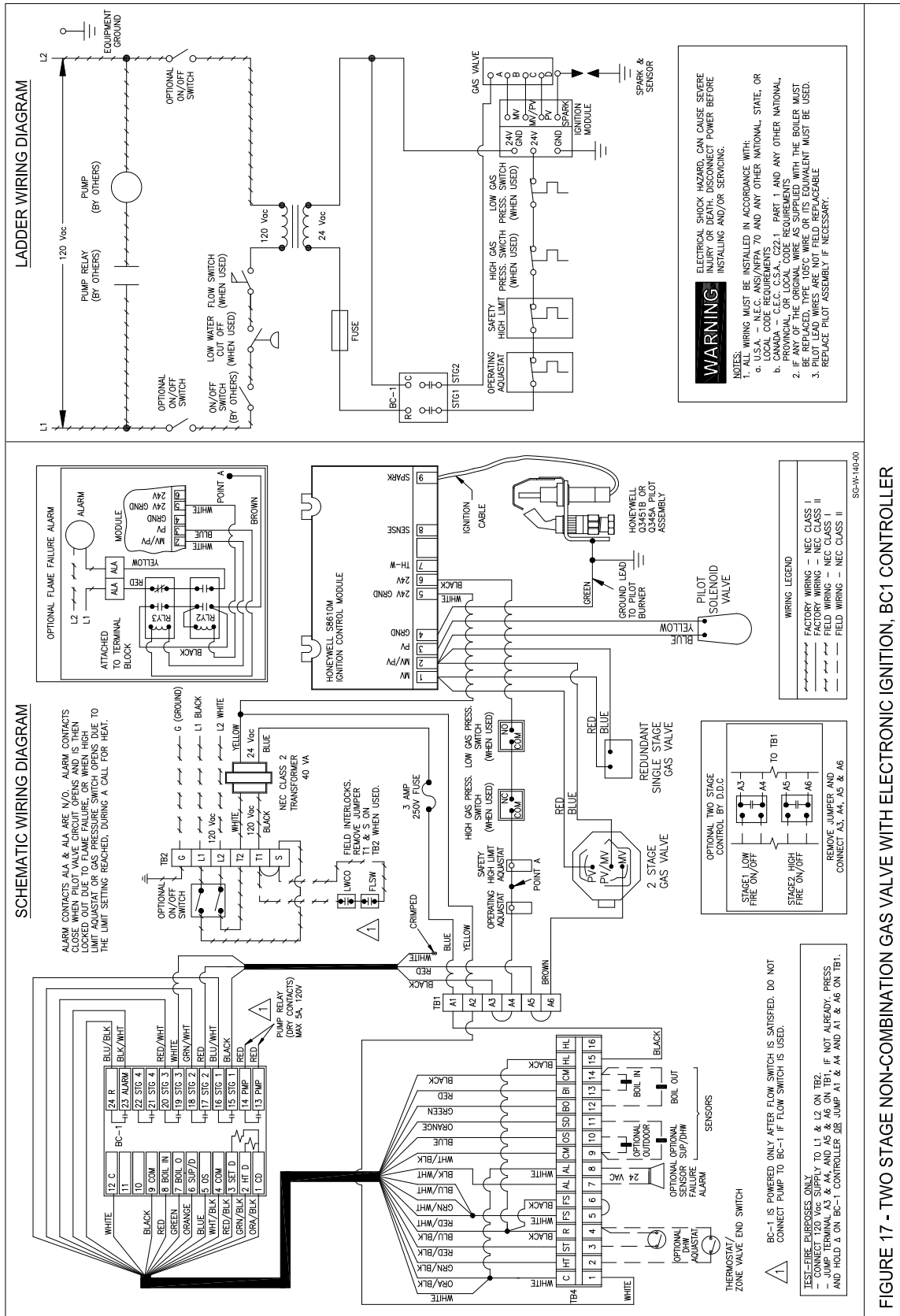

FIGURE 17 - TWO STAGE NON-COMBINATION GAS VALVE WITH ELECTRONIC IGNITION, BC1 CONTROLLER



**TROUBLESHOOTING** **Section 7**

Problem	Possible Cause	Solution
Boiler will not fire	• No power	• Check power switches and wiring
	• No gas supply to boiler	• Check gas source and pressure
	• Gas supply pipes are not purged of air	• Purge gas line
	• No heat demand	• Check if thermostat setting is above room temperature and aquastat setting is above boiler water temperature
	• Flame roll-out or blocked vent safety switch is not reset	• Push reset and diagnose cause
	• Flow switch or low water cut off	• Check pump capacity & flow direction. Check for correct water levels and air locks
	• Gas valve failure (closed position)	• Check gas valve and replace if necessary
	• Thermocouple failure	• Check thermocouple and replace if necessary
	• Faulty wiring	• Check wiring of Aquastats, zone valves, and thermostats for loose or broken wires and repair
	• Faulty controller, aquastat, thermostat, or zone valve	• Check and replace if necessary
• Pilot not lit	• See "Pilot flame will not light on electronic ignition")	
Boiler goes on and off at frequent intervals	• Poor flow in boiler or circulator failure	• Check pump for proper capacity & flow direction. Replace if necessary
	• Thermostat, heat anticipator, or aquastat set too low	• Check and adjust
	• Boiler oversized or insufficient radiation	• Check and adjust if necessary
	• Wrong type of thermostat or controller	• Check and replace if necessary
Boiler fires continuously	• Gas valve failure (open position)	• Check gas valve, replace if necessary
	• Faulty wiring	• Check wiring of Aquastats, zone valves, and thermostats for short circuits or incorrect wiring
	• Faulty controller, aquastat, thermostat, or zone valve	• Check and replace if necessary
Rumbling and moaning sound in boiler	• Boiler is overheated and safety high limit aquastat fails to cut out	• Check Aquastats and adjust or replace if necessary
	• Improper wiring	• Check and correct
	• Foreign matter in heat exchanger	• Flush heat exchanger if necessary
	• Poor circulation	• Check pump for correct flow
	• Air trapped in heating system	• Purge air
Gas odor	• Negative draft	• Incorrect vent size or blocked vent
	• Insufficient combustion air to boiler	• Check combustion and ventilation air opening in boiler room meets installation code requirements, and combustion air flow openings in the boiler base and burner tray are not blocked
	• Leak in gas system	• See "What to do if you smell gas" on cover • Have gas fitter test system and repair leaks
Flame roll out on ignition or during operation	• Carbon build up on the heat exchanger caused by improper venting, ventilation air or low return water temperature	• Have a qualified service technician inspect and clean the heat exchanger as well as check and adjust the system
	• Negative draft	• Check venting



<b>Problem</b>	<b>Possible Cause</b>	<b>Solution</b>
Pilot flame will not light on electronic ignition	• No spark	• High voltage wiring is loose, broken or grounded. Repair wiring
	• Ignition electrodes are damaged	• Replace electrodes
	• Ignition electrodes improperly adjusted	• Correct adjustment of electrode
	• Faulty electronic ignition controller	• Replace controller
	• No gas	• Confirm supply of gas to pilot and repair if necessary
	• Gas supply pipes not purged of air	• Purge gas line
	• Low pilot gas pressure	• Adjust pressure
	• Dirt or foreign material in pilot	• Clean
Pilot lights but flame failure after trial for ignition	• Incorrect pilot flame pressure	• Set pilot pressure to correct pressure
	• Poor connections in wiring to flame sensor	• Repair wiring
	• Electrodes are damaged	• Replace electrodes
	• Ignition electrodes improperly adjusted.	• Correct adjustment of electrodes
Burner starts but flame will not stay established	• Ignition electrodes are wet, dirty or improperly adjusted (for electronic ignition only)	• Check, clean, change and/or adjust the electrodes
	• Poor connections in wiring to flame sensor	• Repair wiring
Boiler carbonizes (forms soot) quickly	• Incorrect orifice sizing	• Check orifice and replace if necessary
	• Inadequate combustion and ventilation air	• Check and adjust
	• Dusty environment	• Clean
	• Low return water temperature	• Adjust system
	• Manifold pressure too high	• Adjust manifold pressure
Boiler overheats and system remains cold	• Insufficient circulation	• Check pump, clean and replace if necessary
	• Air trapped in piping	• Purge system
	• Improper system wiring	• Test and correct
Boiler and heating system overheat	• Faulty thermostat or controller	• Check, adjust, and replace if necessary
	• Faulty aquastat and/or safety high limit aquastat	• Check, adjust, and replace if necessary
	• Faulty wiring	• Check wiring for short circuits and repair



**NOTES**

**Section 8**



# SG Series Boilers – Installation and Service Manual



## **ALLIED TECHNOLOGIES**

Division of E-Z-Rect Manufacturing Ltd.

Manufacturers of Gas and Electric Boilers, Heat Exchangers, Electric Boosters, Indirect Tanks  
94 Riverside Drive, North Vancouver, B.C. V7H 2M6 • Telephone 604-929-1214 • [www.alliedboilers.com](http://www.alliedboilers.com)  
Branches: Calgary • Edmonton • Toronto • Denver